





PRODUCT CATALOG

Shielding and Grounding

KITAGAWA INDUSTRIES America, Inc.

 <http://KGS-IND.com>

 Sales@KGS-IND.com

 Toll Free: 1-855-EMC-PART

Cable Shielding Solution Products



Prior to using KGS parts please read our "Product Important Notice" at <http://kgs-ind.com/products/product-important-notice/>



Mesh Tape (MT series)

- Very flexible cylindrical mesh made of extremely fine (0.12mm), braided, tin-plated copper wires
- Can be easily wrapped around the cable or insert cables through the mesh cylinder
- Conforms to irregular shapes and surfaces
- Tin-plating allows for low impedance and resists galvanic corrosion, and copper provides excellent conductivity
- Can be terminated for grounding at the ends of the cable
- Can also solder to application if needed (to ground permanently)

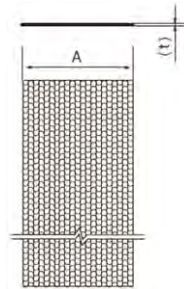

Sn plating (Low impedance, excellent against galvanic corrosion)
Copper (Excellent conductivity)

Part No.	Dimensions		
	A (mm)	Length (m)	(t)
MT-17-CT	17	300	0.4
MT-25-CT	25	200	
MT-30-CT	30	150	
MT-35-CT	35	100	
MT-40-CT	40	100	
MT-55-CT	55	50	0.8
MT-85-CT	85	25	
MT-95-CT	95	25	
MT-120-CT	120	25	
MT-150-CT	150	25	
MT-175-CT	175	25	
MT-230-CT	230	25	



FRCSR series

- Lightweight, flexible cable shielding jacket effective for EMI shielding
- Features adhesive tape closure (no tools necessary for installation), aluminum conductive layer, and polyurethane and PET film insulation layer
- Designed for flat cables and can be installed easily on terminated cables
- Optional grounding wire
- Standard length = 960mm

Outer polyurethane and PET film insulation layer
Inner aluminum foil conductive layer

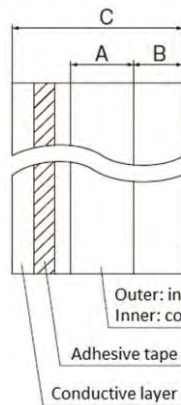
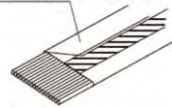

FRCSR	
Conductive material and thickness	Aluminum foil 10µm
Outer insulation layer and thickness	Polyurethane + PET film 125µm
Closure	Double sided PSA with release liner
Color (outer layer)	Black
Maximum Length	960mm

Part No.	A	B	C
FRCSR-15	15	14	43
FRCSR-22	22	17	59
FRCSR-28	28	26	80
FRCSR-35	35	29	93
FRCSR-40	40	35	110
FRCSR-46	46	36	118
FRCSR-53	53	45	143
FRCSR-66	66	56	178

Units: mm

Please request for detailed product specification data prior to purchase.



KITAGAWA INDUSTRIES America, Inc.
2325 Paragon Drive, Suite 10, San Jose, CA 95131
Tel: (408) 971-2055 Fax: (408) 971-6033
www.kgs-ind.com sales@kgs-ind.com

All statements, specifications, properties, technical information, and recommendations herein are based on tests; however, the accuracy and completeness are not guaranteed and are subject to change without notice due to product improvement and specification change. This statement is made in lieu of all warranties, expressed or implied, including the implied warranties of marketability, and fitness for purpose. KITAGAWA INDUSTRIES America, Inc. obligation under this warranty shall be limited to replacement of product that proves to be defective. Prior to use, the user shall determine the suitability of the product for its intended use, and the user assumes all risk and liability whatsoever in connection therewith. KITAGAWA INDUSTRIES America, Inc. shall have no liability for any injury, loss, or damage arising out of the use of or the inability to use the products. No statement or recommendation contained herein shall have any force or effect unless in an agreement signed by officers of seller and manufacturer.

Volume resistivity stated on our EMI absorber flyer is meant for noise control parameters, where the absorber is considered a conductor, but not for insulation performance. Care should be taken when using absorbers. KITAGAWA INDUSTRIES America, Inc. makes no guarantees as to electrical resistivity values and accepts no liability due to short circuits where EMI absorbers are used directly on a PC Board or areas near high voltage such as for power. The products are designed for EMI noise reduction for electronics. This is not recommended for applications involving human life or extremely high accuracy. Prior to using the products in production, please verify their performance or adhesive strength of PSA for long term use. Avoid applying any external stress such as bending or high amounts of tension. Note when the absorber products are cut, bent, or pulled, there may be a possibility of creating cracks. For storage, keep products in a cool, dry, well-ventilated area at room temperature and avoid high temperatures, humidity, and direct sunlight.

Please contact the sales department at KITAGAWA INDUSTRIES America, Inc. for the use of our products prior to selecting the parts for your application.

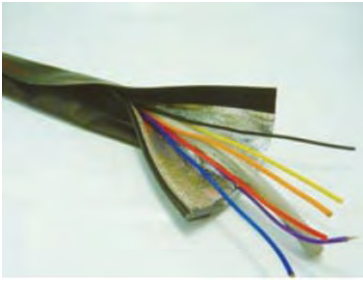

ECBR-AL series

- Convenient for debugging
- Features nylon hook and loop (velcro) fastener for easy application
- Made of conductive aluminum layer, PET fabric-based polyurethane insulation layer, tin-plated copper wire for grounding, and PET fabric-based polyurethane enforcement tape
- Fastener is melted onto the fabric which allows for easy cutting to desired lengths without detachment
- Can be installed on pre-connected cables
- Standard length = 25meters

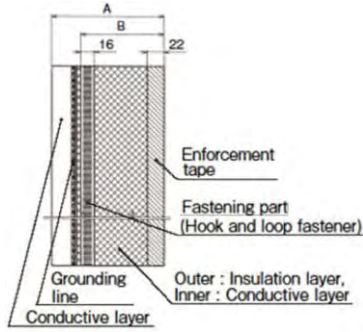

ECBR-AL	
Conductive material and thickness	Aluminum foil 20µm
Outer Insulation layer and thickness	PET fabric-based polyurethane 300µm
Closure	velcro
Color (outer layer)	Black
Standard Length	25meters

Part No.	A	B
ECBR-AL-15G	83	64
ECBR-AL-20G	135	100
ECBR-AL-30G	165	130
ECBR-AL-40G	195	160
ECBR-AL-50G	240	195
ECBR-AL-70G	295	240
ECBR-AL-100G	415	350

Unit: mm



ECBR-CF series

- Lightweight and flexible cable shielding material
- Features nylon hook and loop fastener for easy application
- Nickel-copper conductive fabric layer, PET fabric-based polyurethane insulation layer, and tin-plated copper wire for grounding
- Can be installed on pre-connected or wound cables, ideal for multiple use
- Standard length = 25meters

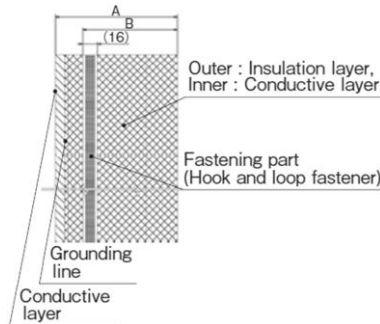

ECBR-CF	
Conductive material and thickness	Conductive fabric 160µm
Outer Insulation layer and thickness	PET fabric-based polyurethane 300µm
Closure	velcro
Color (outer layer)	Black
Standard Length	25meters

Part No.	A	B
ECBR-CF-20G	134	104
ECBR-CF-30G	164	134
ECBR-CF-40G	194	164
ECBR-CF-50G	224	194

Unit: mm

*Please contact us for sizes not listed above

MAGNEFILM MFMAL Series

NEW

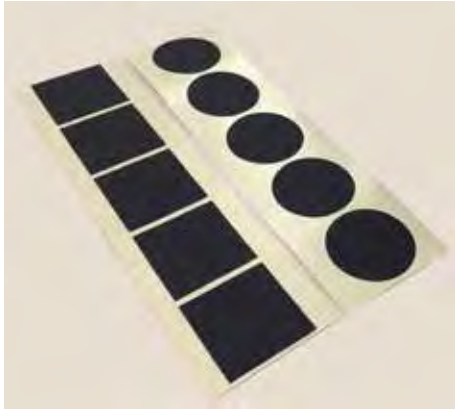

Thin film for magnetic shielding in low-frequencies

- High shielding effectiveness in low frequencies of 100 k to 1 MHz
- Insulation by laminated layer. (Without end face)
- Easy mounting with adhesives
- Cutting service is available upon request
*Size limit (Max: length: 110mm, Max: width: 40mm)

■ Product Structure

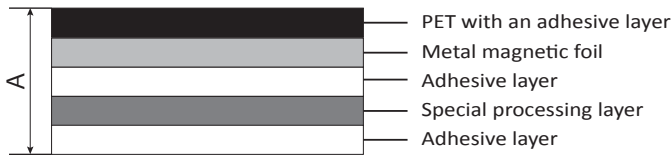

Property	Test Method	MFMAL
Thickness A (mm)	—	0.127
Color	—	Black

■ Properties

Magnetic shielding effectiveness (KEC method)

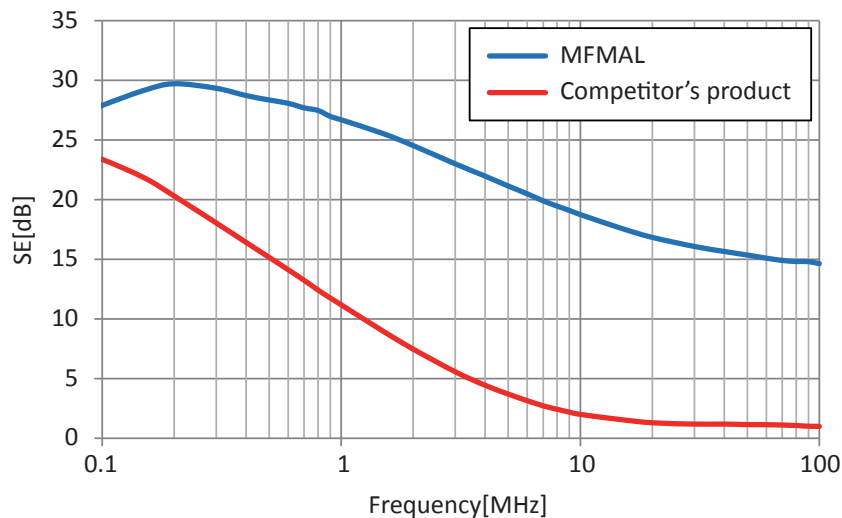

2860 Zanker Road Suite 102, San Jose, CA 95134

Tel: 1-855-EMC-PART (1-855-362-7278) Email: sales@kgs-ind.com

All statements, specifications, properties, technical information, and recommendations herein are based on tests; however, the accuracy and completeness are not guaranteed and are subject to change without notice due to product improvement and specification change. This statement is made in lieu of all warranties, expressed or implied, including the implied warranties of marketability, and fitness for purpose. KITAGAWA INDUSTRIES America, Inc. obligation under this warranty shall be limited to replacement of product that proves to be defective. Prior to use, the user shall determine the suitability of the product for its intended use, and the user assumes all risk and liability whatsoever in connection therewith. KITAGAWA INDUSTRIES America, Inc. shall have no liability for any injury, loss, or damage arising out of the use of or the inability to use the products. No statement or recommendation contained herein shall have any force or effect unless in an agreement signed by officers of seller and manufacturer.

www.kgs-ind.com

Please request for detailed product specification data prior to purchase

Volume resistivity stated on our EMI absorber flyer is meant for noise control parameters, where the absorber is considered a conductor, but not for insulation performance. Care should be taken when using absorbers. KITAGAWA INDUSTRIES America, Inc. makes no guarantees as to electrical resistivity values and accepts no liability due to short circuits where EMI absorbers are used directly on a PC Board or areas near high voltage such as for power. The products are designed for EMI noise reduction for electronics. This is not recommended for applications involving human life or extremely high accuracy. Prior to using the products in production, please verify their performance or adhesive strength of PSA for long term use. Avoid applying any external stress such as bending or high amounts of tension. Note when the absorber products are cut, bent, or pulled, there may be a possibility of creating cracks. For storage, keep products in a cool, dry, well-ventilated area at room temperature and avoid high temperatures, humidity, and direct sunlight.

Please contact the sales department at KITAGAWA INDUSTRIES America, Inc. for the use of our products prior to selecting the parts for your application.

MAGNEFILM_MFMAL Series_REV0_05092019

Mesh Tape MT Series



Very flexible cylindrical mesh made of extremely fine (0.12mm), braided, tin-plated copper wires

- Can be easily wrapped around the cable or insert cables through the mesh cylinder
- Conforms to irregular shapes and surfaces
- Tin-plating allows for low impedance and resists galvanic corrosion, and copper provides excellent conductivity
- Can be terminated for grounding at the ends of the cable
- Can also solder to application if needed (to ground permanently)

■ Dimensions

Part Number	A	(t)
MT-17-CT	17	0.4
MT-25-CT	25	0.4
MT-30-CT	30	0.4
MT-35-CT	35	0.4
MT-40-CT	40	0.4
MT-55-CT	55	0.8
MT-85-CT	85	0.8
MT-95-CT	95	0.8
MT-120-CT	120	0.8
MT-150-CT	150	0.8
MT-175-CT	175	0.8
MT-230-CT	230	0.8

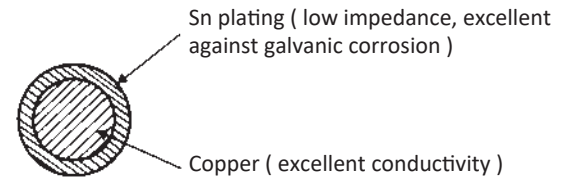
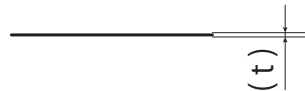
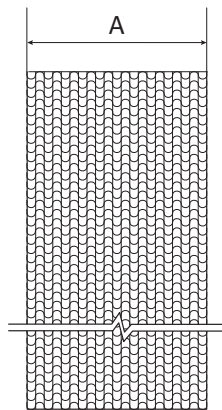

All statements, specifications, properties, technical information, and recommendations herein are based on tests; however, the accuracy and completeness are not guaranteed and are subject to change without notice due to product improvement and specification change. This statement is made in lieu of all warranties, expressed or implied, including the implied warranties of marketability, and fitness for purpose. KITAGAWA INDUSTRIES America, Inc. obligation under this warranty shall be limited to replacement of product that proves to be defective. Prior to use, the user shall determine the suitability of the product for its intended use, and the user assumes all risk and liability whatsoever in connection therewith. KITAGAWA INDUSTRIES America, Inc. shall have no liability for any injury, loss, or damage arising out of the use of or the inability to use the products. No statement or recommendation contained herein shall have any force or effect unless in an agreement signed by officers of seller and manufacturer.

KGS KITAGAWA INDUSTRIES America, Inc.

2860 Zanker Road Suite 102, San Jose, CA 95134

Tel: 1-855-EMC-PART (1-855-362-7278) Email: sales@kgs-ind.com

www.kgs-ind.com

Please request for detailed product specification data prior to purchase

Volume resistivity stated on our EMI absorber flyer is meant for noise control parameters, where the absorber is considered a conductor, but not for insulation performance. Care should be taken when using absorbers. KITAGAWA INDUSTRIES America, Inc. makes no guarantees as to electrical resistivity values and accepts no liability due to short circuits where EMI absorbers are used directly on a PC Board or areas near high voltage such as for power. The products are designed for EMI noise reduction for electronics. This is not recommended for applications involving human life or extremely high accuracy. Prior to using the products in production, please verify their performance or adhesive strength of PSA for long term use. Avoid applying any external stress such as bending or high amounts of tension. Note when the absorber products are cut, bent, or pulled, there may be a possibility of creating cracks. For storage, keep products in a cool, dry, well-ventilated area at room temperature and avoid high temperatures, humidity, and direct sunlight.

Please contact the sales department at KITAGAWA INDUSTRIES America, Inc. for the use of our products prior to selecting the parts for your application.

Mesh Tape_MT Series_REV0_08172018

Cable Shielding Jacket

FRCSE Series



Flexible shielding jacket to protect cables from EMI noise

- Easily installed on connected cables for immediate shielding against emissions or immunity noise
- Great for retrofit work
- Adhesive closure allows for quick and simple finish
- Can be applied to flat or round cables and cable bundles
- Braided grounding wire included throughout the length of the jacket
- Standard roll length is 25 meters
- Cut lengths available upon request

Specifications

	FRCSE
Conductive Inner Shield Material	Aluminum
Conductive Inner Shield Thickness (mm)	0.01
Total Thickness (mm)	0.24
Color (outer PVC layer)	Black
Closure Type	Double sided PSA with release liner
Surface Resistance (Ω/\square)	<0.1
Operating Temperature ($^{\circ}\text{C}$)	-10 ~ +45
Standard Roll Length (meters)	25

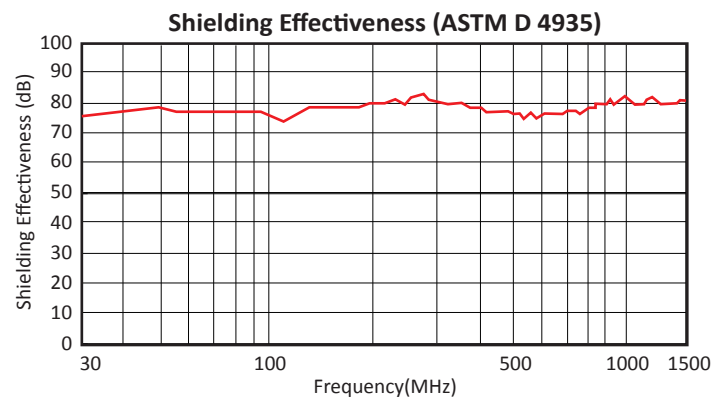

Sizes

Part Number	Width (mm)	Braided ground wire width (mm)
FRCSE-15	15	12
FRCSE-23	23	12
FRCSE-28	28	25
FRCSE-35	35	25
FRCSE-46	46	25
FRCSE-53	53	25
FRCSE-66	66	25
FRCSE-79	79	25
FRCSE-92	92	25

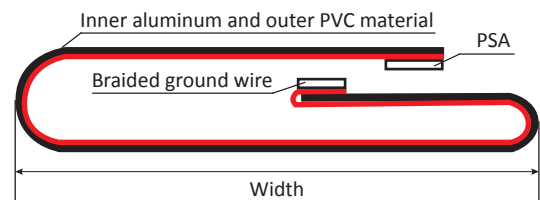

All statements, specifications, properties, technical information, and recommendations herein are based on tests; however, the accuracy and completeness are not guaranteed and are subject to change without notice due to product improvement and specification change. This statement is made in lieu of all warranties, expressed or implied, including the implied warranties of marketability, and fitness for purpose. KITAGAWA INDUSTRIES America, Inc. obligation under this warranty shall be limited to replacement of product that proves to be defective. Prior to use, the user shall determine the suitability of the product for its intended use, and the user assumes all risk and liability whatsoever in connection therewith. KITAGAWA INDUSTRIES America, Inc. shall have no liability for any injury, loss, or damage arising out of the use of or the inability to use the products. No statement or recommendation contained herein shall have any force or effect unless in an agreement signed by officers of seller and manufacturer.

Please request for detailed product specification data prior to purchase

Volume resistivity stated on our EMI absorber flyer is meant for noise control parameters, where the absorber is considered a conductor, but not for insulation performance. Care should be taken when using absorbers. KITAGAWA INDUSTRIES America, Inc. makes no guarantees as to electrical resistivity values and accepts no liability due to short circuits where EMI absorbers are used directly on a PC Board or areas near high voltage such as for power. The products are designed for EMI noise reduction for electronics. This is not recommended for applications involving human life or extremely high accuracy. Prior to using the products in production, please verify their performance or adhesive strength of PSA for long term use. Avoid applying any external stress such as bending or high amounts of tension. Note when the absorber products are cut, bent, or pulled, there may be a possibility of creating cracks. For storage, keep products in a cool, dry, well-ventilated area at room temperature and avoid high temperatures, humidity, and direct sunlight.

Please contact the sales department at KITAGAWA INDUSTRIES America, Inc. for the use of our products prior to selecting the parts for your application.

Conductive Carbon Rubber CSR Series



Carbon filled based rubber

- Carbon rubber is a good shielding gasket and an excellent environment seal
- Excellent formability available in the form of sheet as well as various extruded shapes as shown below
- Custom cutting available upon request

Specification

Material conductive silicone (black) Continuous use temperature range	-40 ~ 150°C
Hardness	67 (Type A)
Tensile Strength	5.8 MPa
Tensile Elongation	270% >200%
Volume Resistivity	3 ~ 10 Ohms-cm
Flammability	UL94 V0

*The value are measured data for reference, not guaranteed

R Type



Length:10M

Part Number	A
CSR-R-15	1.5
CSR-R-20	2.0
CSR-R-30	3.0
CSR-R-40	4.0
CSR-R-50	5.0
CSR-R-60	6.6

U Type

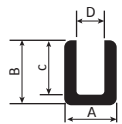

Length:10M

Part Number	A	B	C	D
CSR-U-48-48	4.8	4.8	3.2	1.6
CSR-U-55-110	5.5	11.0	8.0	2.5
CSR-U-80-110	8.0	13.0	9.5	3.5
CSR-U-95-130	9.5	13.0	9.5	5.0

P Type



Length:10M

Part Number	A	B	C
CSR-P-125-50	12.5	5.0	6.0
CSR-P-170-72	17.0	7.2	7.5
CSR-P-240-77	24.0	7.7	11.0

D Type



Length:10M

Part Number	A	B
CSR-D-40-15	4.0	1.5
CSR-D-45-25	4.5	2.5

O Type



Length:10M

Part Number	A	B
CSR-O-25-15	2.5	1.5
CSR-O-60-30	6.0	3.0
CSR-O-65-30	6.5	3.0
CSR-O-100-65	10.0	6.5



Tel:1-855-EMC-PART (1-855-362-7278) Email: sales@kgs-ind.com

All statements, specifications, properties, technical information, and recommendations herein are based on tests; however, the accuracy and completeness are not guaranteed and are subject to change without notice due to product improvement and specification change. This statement is made in lieu of all warranties, expressed or implied, including the implied warranties of marketability, and fitness for purpose. KITAGAWA INDUSTRIES America, Inc. obligation under this warranty shall be limited to replacement of product that proves to be defective. Prior to use, the user shall determine the suitability of the product for its intended use, and the user assumes all risk and liability whatsoever in connection therewith. KITAGAWA INDUSTRIES America, Inc. shall have no liability for any injury, loss, or damage arising out of the use of or the inability to use the products. No statement or recommendation contained herein shall have any force or effect unless in an agreement signed by officers of seller and manufacturer.

www.kgs-ind.com

Please request for detailed product specification data prior to purchase

Volume resistivity stated on our EMI absorber flyer is meant for noise control parameters, where the absorber is considered a conductor, but not for insulation performance. Care should be taken when using absorbers. KITAGAWA INDUSTRIES America, Inc. makes no guarantees as to electrical resistivity values and accepts no liability due to short circuits where EMI absorbers are used directly on a PC Board or areas near high voltage such as for power. The products are designed for EMI noise reduction for electronics. This is not recommended for applications involving human life or extremely high accuracy. Prior to using the products in production, please verify their performance or adhesive strength of PSA for long term use. Avoid applying any external stress such as bending or high amounts of tension. Note when the absorber products are cut, bent, or pulled, there may be a possibility of creating cracks. For storage, keep products in a cool, dry, well-ventilated area at room temperature and avoid high temperatures, humidity, and direct sunlight.

Please contact the sales department at KITAGAWA INDUSTRIES America, Inc. for the use of our products prior to selecting the parts for your application.

Conductive Carbon Rubber_CSR Series_REV0_09102020

EMI Gaskets NLCG Series



Fabric-over-foam gasket with low surface resistance for excellent shielding effectiveness and ESD mitigation

- Excellent shielding properties from 10 MHz and above
- Easy to process and cut to length

Part Number Example

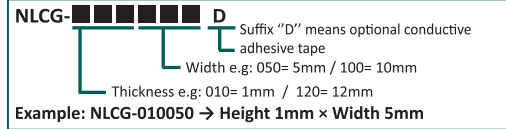

Specification

Property	NLCG Series
Material	Nickel-cooper plated, Woven polyester fabric over polyurethane foam with non-conductive adhesive
Flame Resistance	UL94 V0 (File No. E223669)
Operating Temperature (°C)	-20 ~ +70

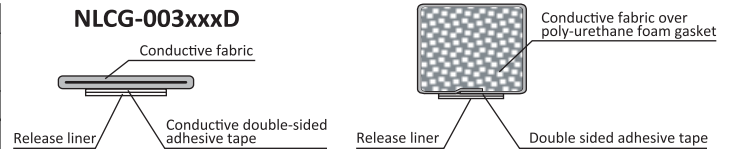

Characteristics

Compression Force Test and Resistance Test

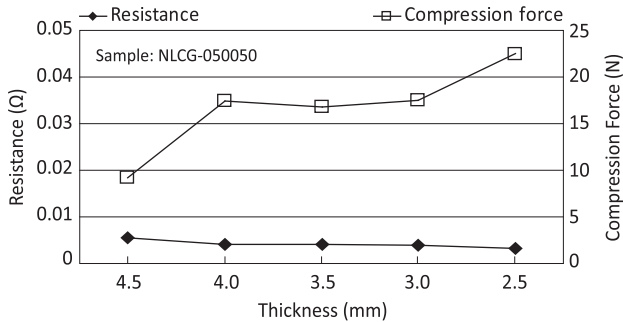

Size Variation

Height	Double sided adhesive tape type								Conductive adhesive tape type				
	Width 5	6	7	10	13	15	21	30	35				
0.3	○											○	
1	●○		●○	●○									
1.5	●○		●○	●○									
2	●○		●○	●○									
3	●○			●○									
4	●○			●○	●								
5	●○			●○									
6		●		●									
7				●	●								
10				●									
12				●									
15								●					

Unit: mm

Application Example

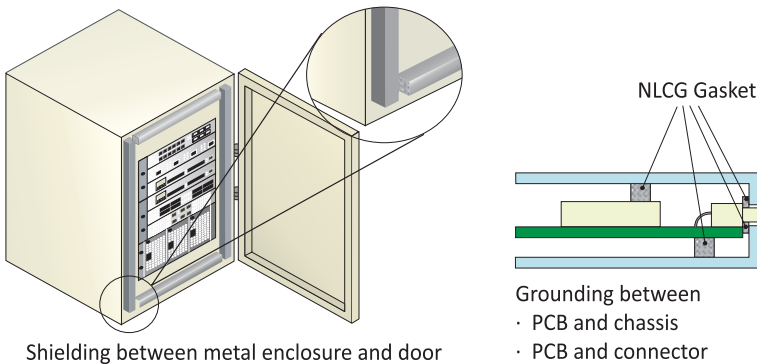

Die-cut Capabilities

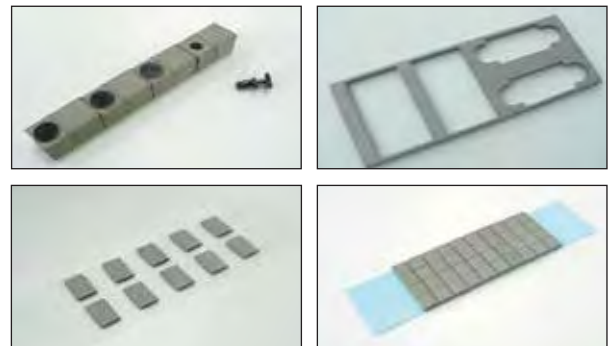

Please request for detailed product specification data prior to purchase

Volume resistivity stated on our EMI absorber flyer is meant for noise control parameters, where the absorber is considered a conductor, but not for insulation performance. Care should be taken when using absorbers. KITAGAWA INDUSTRIES America, Inc. makes no guarantees as to electrical resistivity values and accepts no liability due to short circuits where EMI absorbers are used directly on a PC Board or areas near high voltage such as for power. The products are designed for EMI noise reduction for electronics. This is not recommended for applications involving human life or extremely high accuracy. Prior to using the products in production, please verify their performance or adhesive strength of PSA for long term use. Avoid applying any external stress such as bending or high amounts of tension. Note when the absorber products are cut, bent, or pulled, there may be a possibility of creating cracks. For storage, keep products in a cool, dry, well-ventilated area at room temperature and avoid high temperatures, humidity, and direct sunlight.

Please contact the sales department at KITAGAWA INDUSTRIES America, Inc. for the use of our products prior to selecting the parts for your application.



All statements, specifications, properties, technical information, and recommendations herein are based on tests; however, the accuracy and completeness are not guaranteed and are subject to change without notice due to product improvement and specification change. This statement is made in lieu of all warranties, expressed or implied, including the implied warranties of marketability, and fitness for purpose. KITAGAWA INDUSTRIES America, Inc. obligation under this warranty shall be limited to replacement of product that proves to be defective. Prior to use, the user shall determine the suitability of the product for its intended use, and the user assumes all risk and liability whatsoever in connection therewith. KITAGAWA INDUSTRIES America, Inc. shall have no liability for any injury, loss, or damage arising out of the use of or the inability to use the products. No statement or recommendation contained herein shall have any force or effect unless in an agreement signed by officers of seller and manufacturer.

KGS KITAGAWA INDUSTRIES America, Inc.

2325 Paragon Drive, Suite 10, San Jose, CA 95131

Tel: 1-855-EMC-PART (1-855-362-7278) Email: sales@kgs-ind.com

www.kgs-ind.com

EMI Gaskets_NLCG Series_REV0_02122018

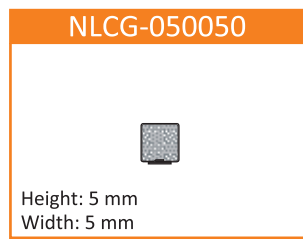
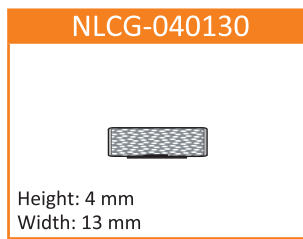
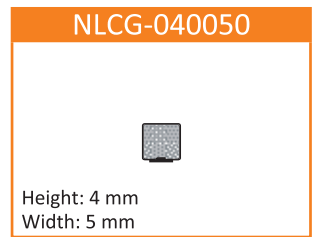
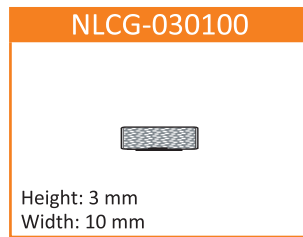
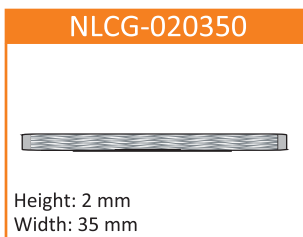
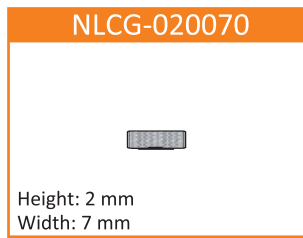
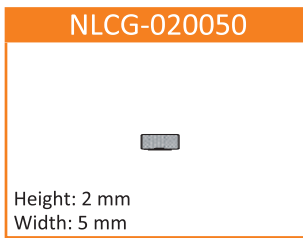
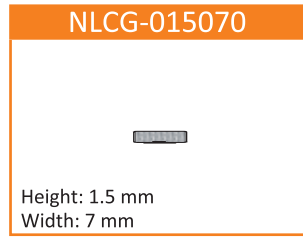
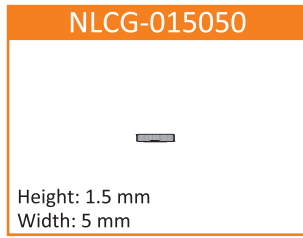
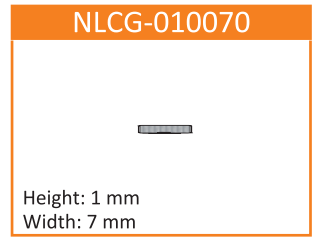
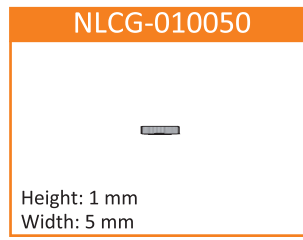

- Please note: Images are not shown to scale
- 0.3 mm thickness is also available as Halogen Free version
- Conductive double-sided adhesive tape available upon request

NEW!

EZ-Foam™

EZ-F Series

RoHS
Compliant

Halogen Free
HF



X, Y, and Z-axis high conductive thin foam for grounding and shielding

- Cost-effective, tarnish-resistant, electrically conductive NiCu-plated polyolefin foam with conductive adhesive
- Excellent surface and volume conductivity
- Ideal for grounding or shielding applications with narrow gaps such as tablets and smart phones, and a great alternative to FoF gaskets for thin spaces
- Excellent shock absorption and vibration damping properties.
- Kiss-cut die cutting for easy application
- Recommended compression rate between 15~30%
- Operating temperature: -10 °C ~ 85 °C

■ Specifications

Property	EZ-FB	EZ-F2
Standard roll size (mm)	Width 500*	Width 500*
	Length 30 meters**	Length 30 meters**
Thickness (mm)	0.2 ± 0.10, 0.3 ± 0.10, 0.5 ± 0.10, 0.7 ± 0.10, 1.0 ± 0.15	0.2 ± 0.10, 0.3 ± 0.10, 0.5 ± 0.10, 0.7 ± 0.10, 1.0 ± 0.15
Color	Black	Grey
Surface Resistance (Ω/sq)	< 0.20 / 1.0mm thick = < 0.30	< 0.10
Volume Resistance (Ω/cm)	< 0.10 / 1.0mm thick = < 0.30	< 0.10
Shielding Effectiveness (dB)	Minimum 50	Minimum 60
Operating Temperature (°C)	-10 ~ +85	-10 ~ +85

*1 meter width available upon request
**50 meter length available upon request

■ Characteristics

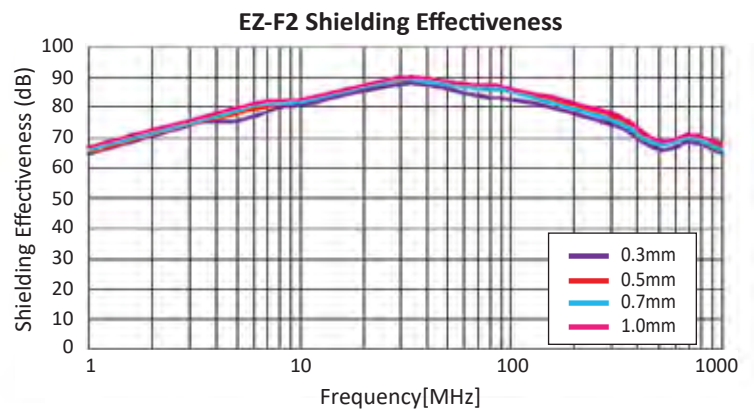
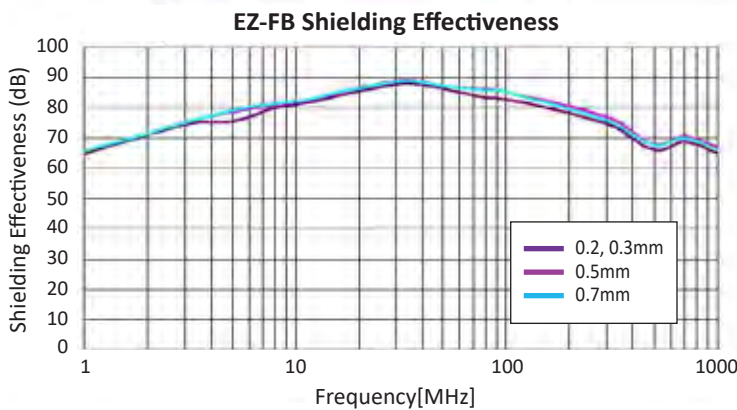

All statements, specifications, properties, technical information, and recommendations herein are based on tests; however, the accuracy and completeness are not guaranteed and are subject to change without notice due to product improvement and specification change. This statement is made in lieu of all warranties, expressed or implied, including the implied warranties of marketability, and fitness for purpose. KITAGAWA INDUSTRIES America, Inc. obligation under this warranty shall be limited to replacement of product that proves to be defective. Prior to use, the user shall determine the suitability of the product for its intended use, and the user assumes all risk and liability whatsoever in connection therewith. KITAGAWA INDUSTRIES America, Inc. shall have no liability for any injury, loss, or damage arising out of the use of or the inability to use the products. No statement or recommendation contained herein shall have any force or effect unless in an agreement signed by officers of seller and manufacturer.

KGS KITAGAWA INDUSTRIES America, Inc.

2860 Zanker Road Suite 102, San Jose, CA 95134

Tel: 1-855-EMC-PART (1-855-362-7278) Email: sales@kgs-ind.com

www.kgs-ind.com

Please request for detailed product specification data prior to purchase

Volume resistivity stated on our EMI absorber flyer is meant for noise control parameters, where the absorber is considered a conductor, but not for insulation performance. Care should be taken when using absorbers. KITAGAWA INDUSTRIES America, Inc. makes no guarantees as to electrical resistivity values and accepts no liability due to short circuits where EMI absorbers are used directly on a PC Board or areas near high voltage such as for power. The products are designed for EMI noise reduction for electronics. This is not recommended for applications involving human life or extremely high accuracy. Prior to using the products in production, please verify their performance or adhesive strength of PSA for long term use. Avoid applying any external stress such as bending or high amounts of tension. Note when the absorber products are cut, bent, or pulled, there may be a possibility of creating cracks. For storage, keep products in a cool, dry, well-ventilated area at room temperature and avoid high temperatures, humidity, and direct sunlight.

Please contact the sales department at KITAGAWA INDUSTRIES America, Inc. for the use of our products prior to selecting the parts for your application.

EZ-Foam_EZ Series_REV0_10262017

EMI SHIELDING TAPES



Part Number Example:
IMCU-HF-20T L=50

CU: Cooper (Material)
HF: Halogen Free
20: 20 mm (Width)
T: PSA (on one side)
L: 50 Meters (Length)

Conductive tapes for shielding and grounding

- Ideal solution for EMI and RF shielding
- Electrically conductive adhesive on one side
- Conductive fabric tape is flexible and wrinkle-free
- RoHS compliant



	Copper	Aluminum	Embossed Copper	Carbon Coated	Nickel Coated
Part Number	IMCU-HF-XXXX L=50	IMAL-HF-XXXX L=50	CCTE-XXX-C	CSTK-XXX	IMCF-HF-XXXX L=50
Adhesive	Conductive Acrylic	Conductive Acrylic	Conductive Acrylic	Conductive Acrylic	Conductive Acrylic
Total Thickness (mm)	0.07 ± 0.01	0.07 ± 0.01	0.13 ± 0.01	0.1 ± 0.025	0.11 ± 0.02
Max Tape Width (mm)	290	1,000	480	300	1,000
Standard Roll Length (m)	50	50	20	20	50
Adhesive Strength	1000 gf / 25mm	1000 gf / 25mm	10.0 N / 25mm	8.5 N / 25mm	1,500 gf / 25mm
Operating Temperature (°C)	-20 ~ 100	-20 ~ 100	-40 ~ 80	-40 ~ 85	-20 ~ 80
Surface Resistance	0.3 Ω / sq	0.3 Ω / sq	0.01 Ω / sq 20mm	0.04 Ω / sq 20mm	0.3 Ω / sq
Z-Axis Resistance	0.05 Ω / in ²	0.05 Ω / in ²	0.008 Ω / 10mm x 100mm	1.59 mΩ / 20mm	0.1 Ω / in ²
Flame Resistance	UL510 Equivalent	UL510 Equivalent	-	UL510FR	UL510 Equivalent
Halogen-Free	Y	Y	Y	N	Y
	Conductive Fabric				



Custom Options

- Standard tape width: 20mm, 25mm, 50mm custom width available
- Die-cut custom size available upon request
- Insulation layer can be added upon request

Cross-sectional view CCTE (embossed copper tape)

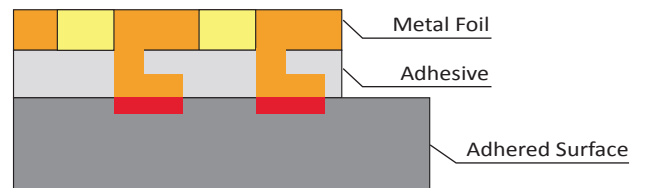

All statements, specifications, properties, technical information, and recommendations herein are based on tests; however, the accuracy and completeness are not guaranteed and are subject to change without notice due to product improvement and specification change. This statement is made in lieu of all warranties, expressed or implied, including the implied warranties of marketability, and fitness for purpose. KITAGAWA INDUSTRIES America, Inc. obligation under this warranty shall be limited to replacement of product that proves to be defective. Prior to use, the user shall determine the suitability of the product for its intended use, and the user assumes all risk and liability whatsoever in connection therewith. KITAGAWA INDUSTRIES America, Inc. shall have no liability for any injury, loss, or damage arising out of the use of or the inability to use the products. No statement or recommendation contained herein shall have any force or effect unless in an agreement signed by officers of seller and manufacturer.

www.kgs-ind.com

Please request for detailed product specification data prior to purchase

Volume resistivity stated on our EMI absorber flyer is meant for noise control parameters, where the absorber is considered a conductor, but not for insulation performance. Care should be taken when using absorbers. KITAGAWA INDUSTRIES America, Inc. makes no guarantees as to electrical resistivity values and accepts no liability due to short circuits where EMI absorbers are used directly on a PC Board or areas near high voltage such as for power. The products are designed for EMI noise reduction for electronics. This is not recommended for applications involving human life or extremely high accuracy. Prior to using the products in production, please verify their performance or adhesive strength of PSA for long term use. Avoid applying any external stress such as bending or high amounts of tension. Note when the absorber products are cut, bent, or pulled, there may be a possibility of creating cracks. For storage, keep products in a cool, dry, well-ventilated area at room temperature and avoid high temperatures, humidity, and direct sunlight.

Please contact the sales department at KITAGAWA INDUSTRIES America, Inc. for the use of our products prior to selecting the parts for your application.

EMI Shielding Tapes_REV1_09102020

Transparent Conductive Film

WINAL Series

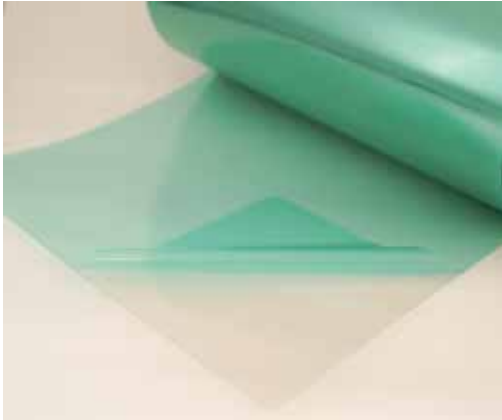

Excellent EMI shielding around LCDs and other apertures



- Low surface electric resistance gives higher shielding effectiveness
- Electrically conductive film with superior optical transparency
- Custom sheet cutting, punching, adhesive tape attachment etc. available upon request

Cross-section view

WINAL75-080

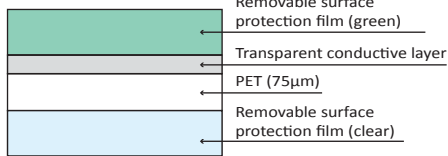

WINAL100-020

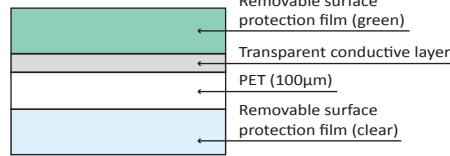

WINAL50-005

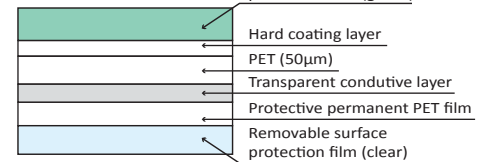

Specification

Part Number	WINAL75-080	WINAL100-020	WINAL50-005
Thickness (µm)	75	100	94
Standard Sheet Size (mm)	420 x 600	210 x 297	200 x 297
Shielding Effectiveness (db/1GHz)	10	22	30
Total Light Transmittance (%) *JIS K 7136	76	76	76
Surface Resistance (Ω/□) *JIS K 7194	80	20	5
Flame Resistance *UL94	VTM-2 equivalent	VTM-2 equivalent	—
Operating Temperature (°C)	-30 - 80	-30 - 80	-30 - 80

*Test method

*Surface protection film not included

NEW

Characteristics

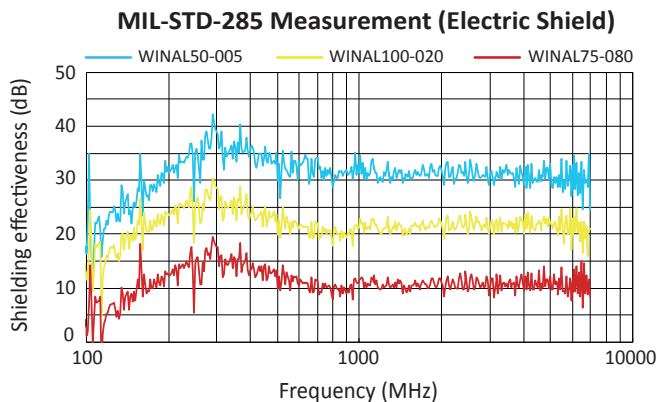

Custom liner options

- Addition of conductive fabric tape layer
- Custom die cutting
- Hole punching

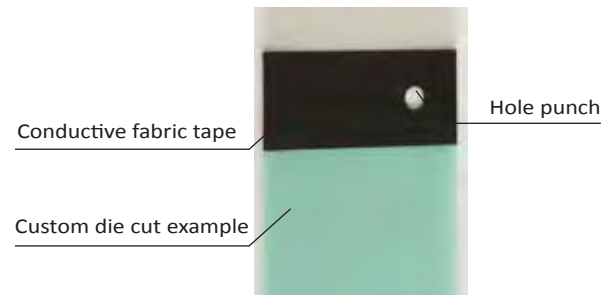

All statements, specifications, properties, technical information, and recommendations herein are based on tests; however, the accuracy and completeness are not guaranteed and are subject to change without notice due to product improvement and specification change. This statement is made in lieu of all warranties, expressed or implied, including the implied warranties of marketability, and fitness for purpose. KITAGAWA INDUSTRIES America, Inc. obligation under this warranty shall be limited to replacement of product that proves to be defective. Prior to use, the user shall determine the suitability of the product for its intended use, and the user assumes all risk and liability whatsoever in connection therewith. KITAGAWA INDUSTRIES America, Inc. shall have no liability for any injury, loss, or damage arising out of the use of or the inability to use the products. No statement or recommendation contained herein shall have any force or effect unless in an agreement signed by officers of seller and manufacturer.

Please request for detailed product specification data prior to purchase

Volume resistivity stated on our EMI absorber flyer is meant for noise control parameters, where the absorber is considered a conductor, but not for insulation performance. Care should be taken when using absorbers. KITAGAWA INDUSTRIES America, Inc. makes no guarantees as to electrical resistivity values and accepts no liability due to short circuits where EMI absorbers are used directly on a PC Board or areas near high voltage such as for power. The products are designed for EMI noise reduction for electronics. This is not recommended for applications involving human life or extremely high accuracy. Prior to using the products in production, please verify their performance or adhesive strength of PSA for long term use. Avoid applying any external stress such as bending or high amounts of tension. Note when the absorber products are cut, bent, or pulled, there may be a possibility of creating cracks. For storage, keep products in a cool, dry, well-ventilated area at room temperature and avoid high temperatures, humidity, and direct sunlight.

Please contact the sales department at KITAGAWA INDUSTRIES America, Inc. for the use of our products prior to selecting the parts for your application.

ULTRA-THIN Conductive Film

REMI Series

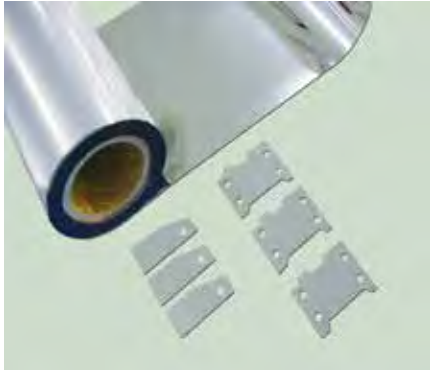

Multi-layer, ultra-thin conductive film

- Thin conductive film with great shielding effectiveness.
- Suitable for shielding noise on flexible cables and small devices with limited clearance.
- Resistant to galvanic corrosion.
- Easier and safer to handle compared to metal conductive tapes.
- Total thickness of REMI-FS and REMI-SC are 35 μ m; REMI-FA and REMI-AC are 55 μ m.

Specifications

Part Number	REMI-FS	REMI-FA	REMI-SC	REMI-AC
Base Material	PET	PET	PPS	PPS
Metal Film	SUS/Cu	SUS/Cu	SUS/Cu	SUS/Cu
Surface Resistance (Ω/\square)*	< 0.5	< 0.5	< 0.5	< 0.5
Total Thickness (mm)	0.035	0.055	0.035	0.055
Adhesive Property	Non-Conductive	Electrically Conductive	Non-Conductive	Electrically Conductive
Flame Rating (UL94)	-	-	UL94 VTM-0 Equivalent**	UL510 FR
Operating Temperature($^{\circ}$ C)	-20 ~ +85	-20 ~ +85	-40 ~ +85	-40 ~ +85
Standard Sheet Size (mm)	210 x 310	220 x 310	210 x 310	220 x 310

*Measured in film form **Not including adhesive

Cross-section view

REMI-FA , REMI-AC: Conductive Adhesive

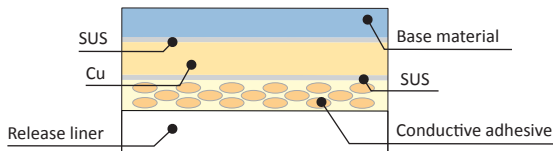

REMI-FS , REMI-SC: Surface Conductive

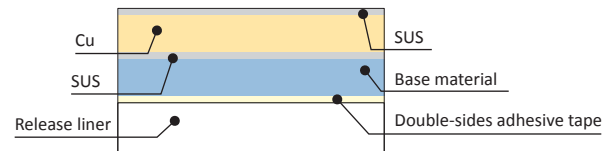

Properties

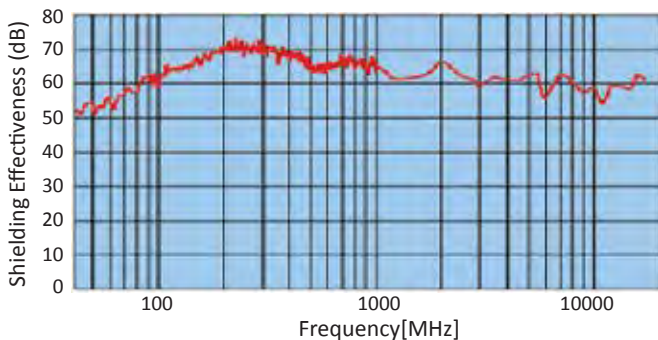

Application Examples

Shielding small boards with surface conductive metal film

REMI-FS/SC

PCB

Shielding and frame grounding of FPC's

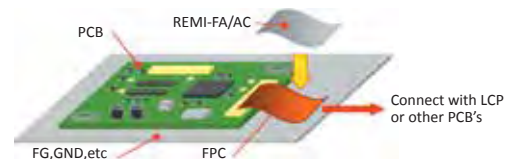

Tel: 1-855-EMC-PART (1-855-362-7278) Email: sales@kgs-ind.com

All statements, specifications, properties, technical information, and recommendations herein are based on tests; however, the accuracy and completeness are not guaranteed and are subject to change without notice due to product improvement and specification change. This statement is made in lieu of all warranties, expressed or implied, including the implied warranties of marketability, and fitness for purpose. KITAGAWA INDUSTRIES America, Inc. obligation under this warranty shall be limited to replacement of product that proves to be defective. Prior to use, the user shall determine the suitability of the product for its intended use, and the user assumes all risk and liability whatsoever in connection therewith. KITAGAWA INDUSTRIES America, Inc. shall have no liability for any injury, loss, or damage arising out of the use of or the inability to use the products. No statement or recommendation contained herein shall have any force or effect unless in an agreement signed by officers of seller and manufacturer.

www.kgs-ind.com

Please request for detailed product specification data prior to purchase

Volume resistivity stated on our EMI absorber flyer is meant for noise control parameters, where the absorber is considered a conductor, but not for insulation performance. Care should be taken when using absorbers. KITAGAWA INDUSTRIES America, Inc. makes no guarantees as to electrical resistivity values and accepts no liability due to short circuits where EMI absorbers are used directly on a PC Board or areas near high voltage such as for power. The products are designed for EMI noise reduction for electronics. This is not recommended for applications involving human life or extremely high accuracy. Prior to using the products in production, please verify their performance or adhesive strength of PSA for long term use. Avoid applying any external stress such as bending or high amounts of tension. Note when the absorber products are cut, bent, or pulled, there may be a possibility of creating cracks. For storage, keep products in a cool, dry, well-ventilated area at room temperature and avoid high temperatures, humidity, and direct sunlight.

Please contact the sales department at KITAGAWA INDUSTRIES America, Inc. for the use of our products prior to selecting the parts for your application.

ULTRA-THIN Conductive Film_REMI Series_REV0_02132018

MAGNEFILM MFMAL Series

NEW



Thin film for magnetic shielding in low-frequencies

- High shielding effectiveness in low frequencies of 100 k to 1 MHz
- Insulation by laminated layer. (Without end face)
- Easy mounting with adhesives
- Cutting service is available upon request
*Size limit (Max: length: 110mm, Max: width: 40mm)

■ Product Structure

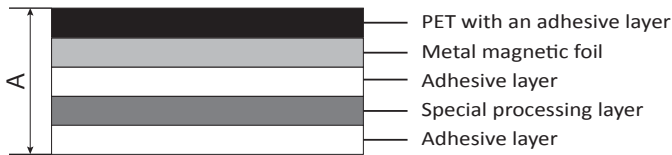

Property	Test Method	MFMAL
Thickness A (mm)	—	0.127
Color	—	Black

■ Properties

Magnetic shielding effectiveness (KEC method)

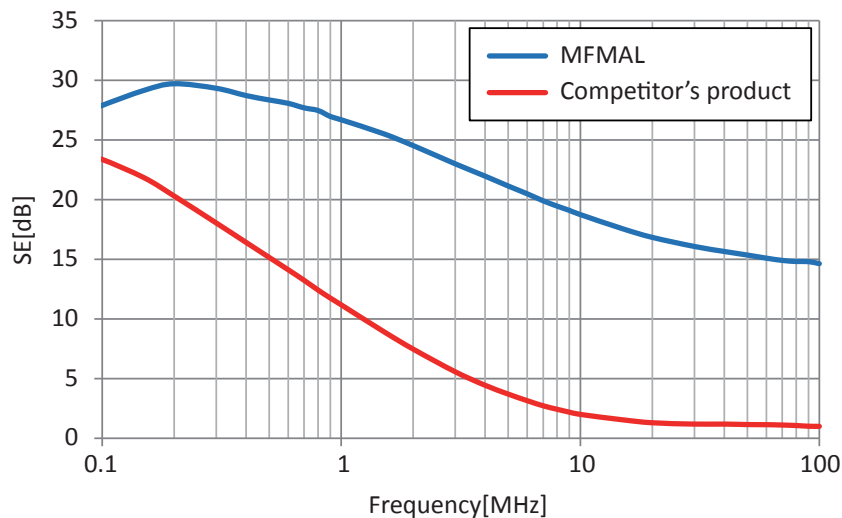

2860 Zanker Road Suite 102, San Jose, CA 95134

Tel: 1-855-EMC-PART (1-855-362-7278) Email: sales@kgs-ind.com

All statements, specifications, properties, technical information, and recommendations herein are based on tests; however, the accuracy and completeness are not guaranteed and are subject to change without notice due to product improvement and specification change. This statement is made in lieu of all warranties, expressed or implied, including the implied warranties of marketability, and fitness for purpose. KITAGAWA INDUSTRIES America, Inc. obligation under this warranty shall be limited to replacement of product that proves to be defective. Prior to use, the user shall determine the suitability of the product for its intended use, and the user assumes all risk and liability whatsoever in connection therewith. KITAGAWA INDUSTRIES America, Inc. shall have no liability for any injury, loss, or damage arising out of the use of or the inability to use the products. No statement or recommendation contained herein shall have any force or effect unless in an agreement signed by officers of seller and manufacturer.

www.kgs-ind.com

Please request for detailed product specification data prior to purchase

Volume resistivity stated on our EMI absorber flyer is meant for noise control parameters, where the absorber is considered a conductor, but not for insulation performance. Care should be taken when using absorbers. KITAGAWA INDUSTRIES America, Inc. makes no guarantees as to electrical resistivity values and accepts no liability due to short circuits where EMI absorbers are used directly on a PC Board or areas near high voltage such as for power. The products are designed for EMI noise reduction for electronics. This is not recommended for applications involving human life or extremely high accuracy. Prior to using the products in production, please verify their performance or adhesive strength of PSA for long term use. Avoid applying any external stress such as bending or high amounts of tension. Note when the absorber products are cut, bent, or pulled, there may be a possibility of creating cracks. For storage, keep products in a cool, dry, well-ventilated area at room temperature and avoid high temperatures, humidity, and direct sunlight.

Please contact the sales department at KITAGAWA INDUSTRIES America, Inc. for the use of our products prior to selecting the parts for your application.

MAGNEFILM_MFMAL Series_REV0_05092019

GHz Shield Sheet GSS-HT Series

NEW

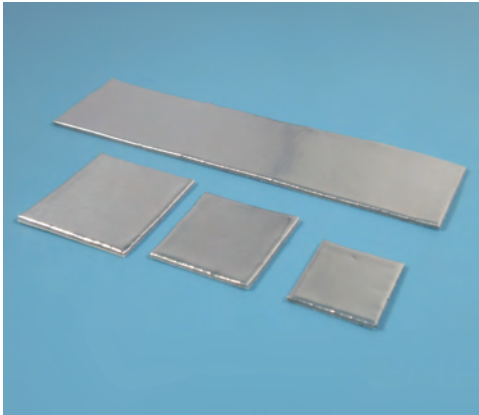

New shielding sheet for GHz band noise

- No trace design of the SHIELD SHEET is required on PC board surfaces, providing high flexibility in circuit design
- Noise suppression in higher frequency band is available without redesign of PC board
- Interference between ICs can be suppressed by applying the sheet shield to each IC

Properties

Property	Test Method	GSS-1.0-HT
Thickness (mm)	—	1.0
Gravity*	JIS K 8807	2.24
Dielectric Constant* (1MHz)	Company Standard	35
Adhesion (N/20mm)	—	12.7
Flame Resistance	UL94	Equivalent to V-0
Operating Temperature (°C)	—	-40 ~ 105
Color*	—	Dark Green

*GHz SHIELD SHEET only

Cross-section view

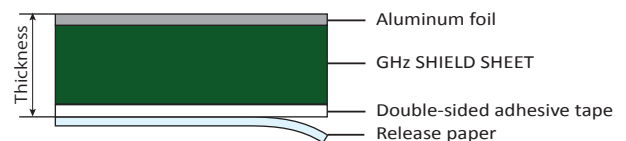

Characteristics

Evaluation results(15GHz、18GHz)

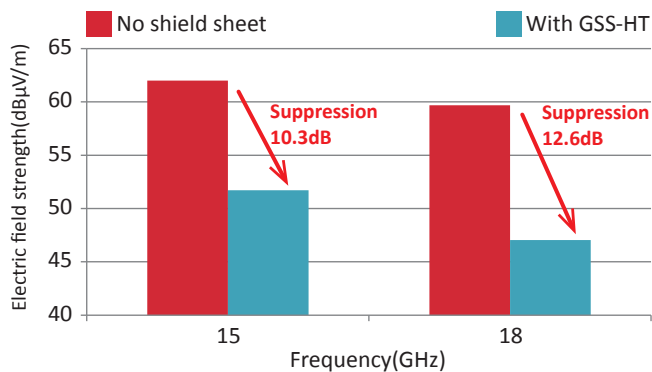

*Suppression in other frequencies may be obtained depending on the sheet size and/or environment.

Test conditions

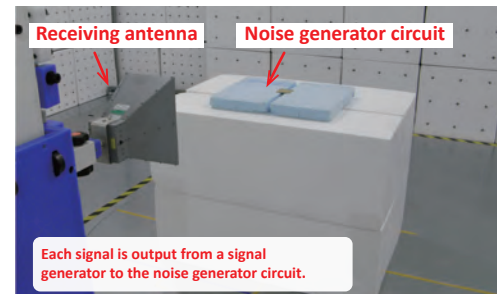

Noise generator circuit

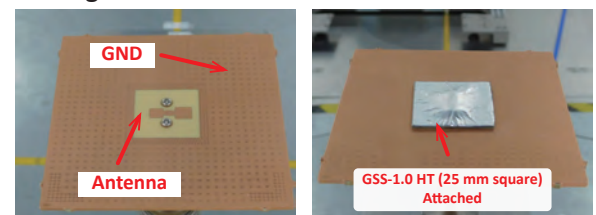

All statements, specifications, properties, technical information, and recommendations herein are based on tests; however, the accuracy and completeness are not guaranteed and are subject to change without notice due to product improvement and specification change. This statement is made in lieu of all warranties, expressed or implied, including the implied warranties of marketability, and fitness for purpose. KITAGAWA INDUSTRIES America, Inc. obligation under this warranty shall be limited to replacement of product that proves to be defective. Prior to use, the user shall determine the suitability of the product for its intended use, and the user assumes all risk and liability whatsoever in connection therewith. KITAGAWA INDUSTRIES America, Inc. shall have no liability for any injury, loss, or damage arising out of the use of or the inability to use the products. No statement or recommendation contained herein shall have any force or effect unless in an agreement signed by officers of seller and manufacturer.

Please request for detailed product specification data prior to purchase

Volume resistivity stated on our EMI absorber flyer is meant for noise control parameters, where the absorber is considered a conductor, but not for insulation performance. Care should be taken when using absorbers. KITAGAWA INDUSTRIES America, Inc. makes no guarantees as to electrical resistivity values and accepts no liability due to short circuits where EMI absorbers are used directly on a PC Board or areas near high voltage such as for power. The products are designed for EMI noise reduction for electronics. This is not recommended for applications involving human life or extremely high accuracy. Prior to using the products in production, please verify their performance or adhesive strength of PSA for long term use. Avoid applying any external stress such as bending or high amounts of tension. Note when the absorber products are cut, bent, or pulled, there may be a possibility of creating cracks. For storage, keep products in a cool, dry, well-ventilated area at room temperature and avoid high temperatures, humidity, and direct sunlight.

Please contact the sales department at KITAGAWA INDUSTRIES America, Inc. for the use of our products prior to selecting the parts for your application.

NEW!

Onboard Contact OG-160810

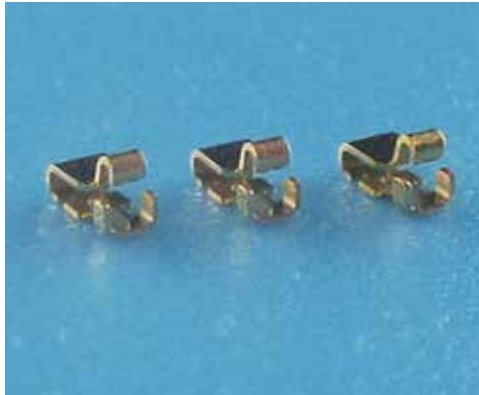

Tiny profile, board-level
EMC grounding component

- Compact design, great for space-conscious applications (such as smart, wearable devices)
- Au plating for stable contact resistance
- Tape-and-reel design for automated mounting

Specifications

Part Number	OG-160810
Recommended Gap (mm)	0.7 ~ 0.9
Material	Beryllium Copper
Surface Treatment	Base: Ni Finish: Partial Au
Operating Temperature (°C)	-40 ~ +125

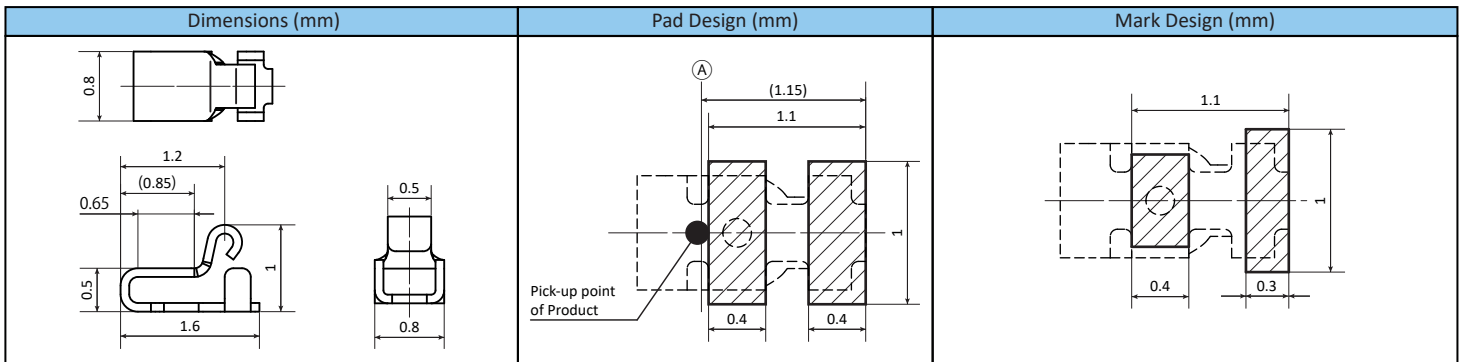

Properties

Compression force vs Electric resistance

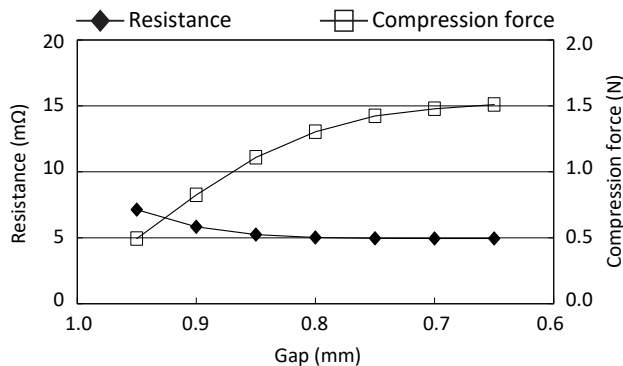

Repetitive compression set

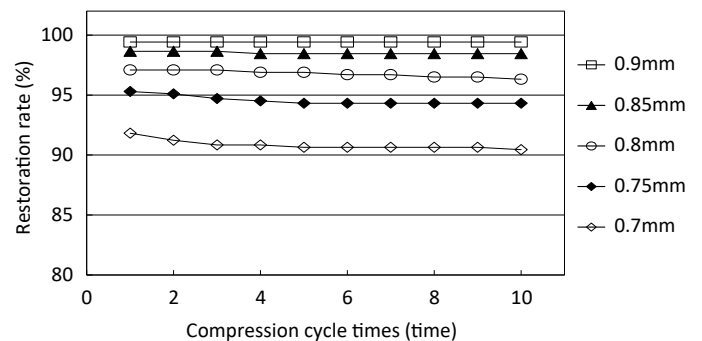

Tel: 1-855-EMC-PART (1-855-362-7278) Email: sales@kgs-ind.com

All statements, specifications, properties, technical information, and recommendations herein are based on tests; however, the accuracy and completeness are not guaranteed and are subject to change without notice due to product improvement and specification change. This statement is made in lieu of all warranties, expressed or implied, including the implied warranties of marketability, and fitness for purpose. KITAGAWA INDUSTRIES America, Inc. obligation under this warranty shall be limited to replacement of product that proves to be defective. Prior to use, the user shall determine the suitability of the product for its intended use, and the user assumes all risk and liability whatsoever in connection therewith. KITAGAWA INDUSTRIES America, Inc. shall have no liability for any injury, loss, or damage arising out of the use of or the inability to use the products. No statement or recommendation contained herein shall have any force or effect unless in an agreement signed by officers of seller and manufacturer.

Please request for detailed product specification data prior to purchase

Volume resistivity stated on our EMI absorber flyer is meant for noise control parameters, where the absorber is considered a conductor, but not for insulation performance. Care should be taken when using absorbers. KITAGAWA INDUSTRIES America, Inc. makes no guarantees as to electrical resistivity values and accepts no liability due to short circuits where EMI absorbers are used directly on a PC Board or areas near high voltage such as for power. The products are designed for EMI noise reduction for electronics. This is not recommended for applications involving human life or extremely high accuracy. Prior to using the products in production, please verify their performance or adhesive strength of PSA for long term use. Avoid applying any external stress such as bending or high amounts of tension. Note when the absorber products are cut, bent, or pulled, there may be a possibility of creating cracks. For storage, keep products in a cool, dry, well-ventilated area at room temperature and avoid high temperatures, humidity, and direct sunlight.

Please contact the sales department at KITAGAWA INDUSTRIES America, Inc. for the use of our products prior to selecting the parts for your application.

On-Board Contact

OG-321605

NEW

HF
Halogen Free



On-board grounding component designed for small gaps

- Low profile contact designed for space conscious applications
- Spring force ensures contact returns to its original height after being fully compressed
- Recommended height: 0.35mm or less
- Applications include mobile devices and wearable gear

Design

Pad Design

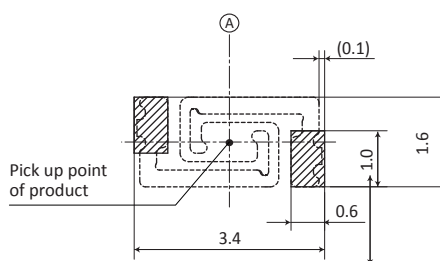

Mask Design

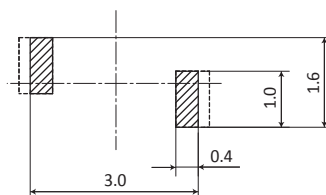

Dimensions

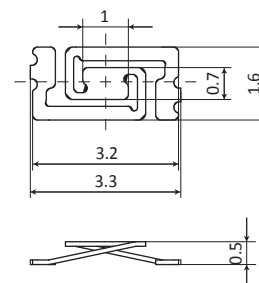

Base material: phosphor bronze for spring (t0.1mm)
Surface treatment: Sn reflow plating, Cu undercoat

Properties

Compression force vs. Electric resistance

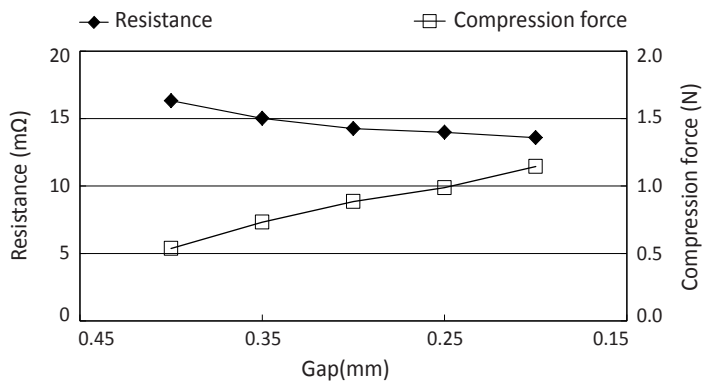

Application

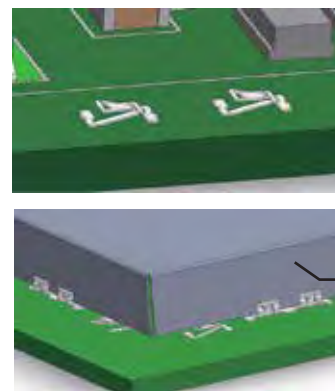

Shielding can

KGS **KGS America**
KITAGAWA INDUSTRIES America, Inc.

Tel: 1-855-EMC-PART (1-855-362-7278) Email: sales@kgs-ind.com

All statements, specifications, properties, technical information, and recommendations herein are based on tests; however, the accuracy and completeness are not guaranteed and are subject to change without notice due to product improvement and specification change. This statement is made in lieu of all warranties, expressed or implied, including the implied warranties of marketability, and fitness for purpose. KITAGAWA INDUSTRIES America, Inc. obligation under this warranty shall be limited to replacement of product that proves to be defective. Prior to use, the user shall determine the suitability of the product for its intended use, and the user assumes all risk and liability whatsoever in connection therewith. KITAGAWA INDUSTRIES America, Inc. shall have no liability for any injury, loss, or damage arising out of the use of or the inability to use the products. No statement or recommendation contained herein shall have any force or effect unless in an agreement signed by officers of seller and manufacturer.

www.kgs-ind.com

Please request for detailed product specification data prior to purchase

Volume resistivity stated on our EMI absorber flyer is meant for noise control parameters, where the absorber is considered a conductor, but not for insulation performance. Care should be taken when using absorbers. KITAGAWA INDUSTRIES America, Inc. makes no guarantees as to electrical resistivity values and accepts no liability due to short circuits where EMI absorbers are used directly on a PC Board or areas near high voltage such as for power. The products are designed for EMI noise reduction for electronics. This is not recommended for applications involving human life or extremely high accuracy. Prior to using the products in production, please verify their performance or adhesive strength of PSA for long term use. Avoid applying any external stress such as bending or high amounts of tension. Note when the absorber products are cut, bent, or pulled, there may be a possibility of creating cracks. For storage, keep products in a cool, dry, well-ventilated area at room temperature and avoid high temperatures, humidity, and direct sunlight.

Please contact the sales department at KITAGAWA INDUSTRIES America, Inc. for the use of our products prior to selecting the parts for your application.

On-Board Contact_OG-321605_REV0_02242020

NEW!

Onboard Contact OG-503253-A



SMT grounding contact for engine compartment PCB

- Spring mechanism capable of withstanding 10 million deflections caused by engine vibration
- Sustained conduction is secured because of unique dimple design
- Can be used under high temperature at 150°C

Specifications

Applications	Ground clip for SMD
Material	Beryllium Copper (t0.12mm)
Applicable Thickness (mm)	3.5 ~ 4.5
Surface Treatment	Sn reflow plating (Primary plating Cu)
Operating Temperature (°C)	-40 ~ 150

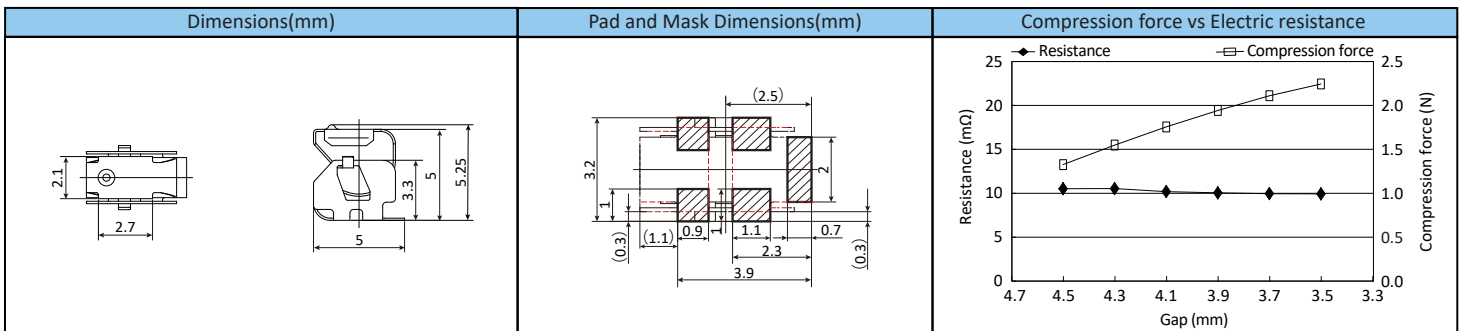

Compression Test

Deflection: H=3.5mm~3.9mm
 Compression count : 10 million times
 Compression speed: 100 times/sec
 Test method: Height measured and visual check after compressed 3.5mm~3.9mm deflections for 10 million times

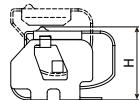

	Before	After
External status		
Height (mm)	5.263	5.226
Recovery rate (%)	—	99.7

Heat-shock Test

Temperature switch: -40°C/150°C (0.5 hour each)
 Number of cycle: 2000 cycles
 Metal plate: Aluminum (ADC 12)
 Test method: Sample is compressed by metal plate while heat is applied. After a set of 250 cycles the DC resistance value is measured

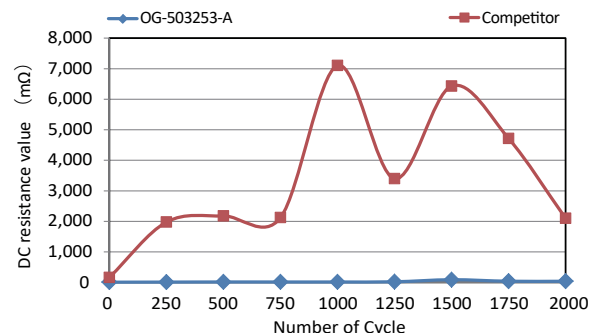

All statements, specifications, properties, technical information, and recommendations herein are based on tests; however, the accuracy and completeness are not guaranteed and are subject to change without notice due to product improvement and specification change. This statement is made in lieu of all warranties, expressed or implied, including the implied warranties of marketability, and fitness for purpose. KITAGAWA INDUSTRIES America, Inc. obligation under this warranty shall be limited to replacement of product that proves to be defective. Prior to use, the user shall determine the suitability of the product for its intended use, and the user assumes all risk and liability whatsoever in connection therewith. KITAGAWA INDUSTRIES America, Inc. shall have no liability for any injury, loss, or damage arising out of the use of or the inability to use the products. No statement or recommendation contained herein shall have any force or effect unless in an agreement signed by officers of seller and manufacturer.

KGS KITAGAWA INDUSTRIES America, Inc.
 2860 Zanker Road Suite 102, San Jose, CA 95134
 Tel: 1-855-EMC-PART (1-855-362-7278) Email: sales@kgs-ind.com

www.kgs-ind.com

Please request for detailed product specification data prior to purchase

Volume resistivity stated on our EMI absorber flyer is meant for noise control parameters, where the absorber is considered a conductor, but not for insulation performance. Care should be taken when using absorbers. KITAGAWA INDUSTRIES America, Inc. makes no guarantees as to electrical resistivity values and accepts no liability due to short circuits where EMI absorbers are used directly on a PC Board or areas near high voltage such as for power. The products are designed for EMI noise reduction for electronics. This is not recommended for applications involving human life or extremely high accuracy. Prior to using the products in production, please verify their performance or adhesive strength of PSA for long term use. Avoid applying any external stress such as bending or high amounts of tension. Note when the absorber products are cut, bent, or pulled, there may be a possibility of creating cracks. For storage, keep products in a cool, dry, well-ventilated area at room temperature and avoid high temperatures, humidity, and direct sunlight.

Please contact the sales department at KITAGAWA INDUSTRIES America, Inc. for the use of our products prior to selecting the parts for your application.

Onboard Contact_OG-503253-A_REV0_06182018

NEW!

Onboard Contact OG-684296

RoHS
Compliant

Automotive
Grade



SMT-type EMC grounding contact for PCB's in engine compartments

- Spring mechanism withstands 10 million compressions from engine vibrations
- Unique dimple design allows for continued electrical contact
- Operating temperature from -40°C ~ +150°C, ideal for automotive applications

Specifications

Applications	Ground Contact for SMD
Material	Beryllium Copper (t0.15mm)
Recommended Gap (mm)	7.0 ~ 9.0
Surface Treatment	Sn reflow plating (Primary plating Cu)
Operating Temperature (°C)	-40 ~ 150

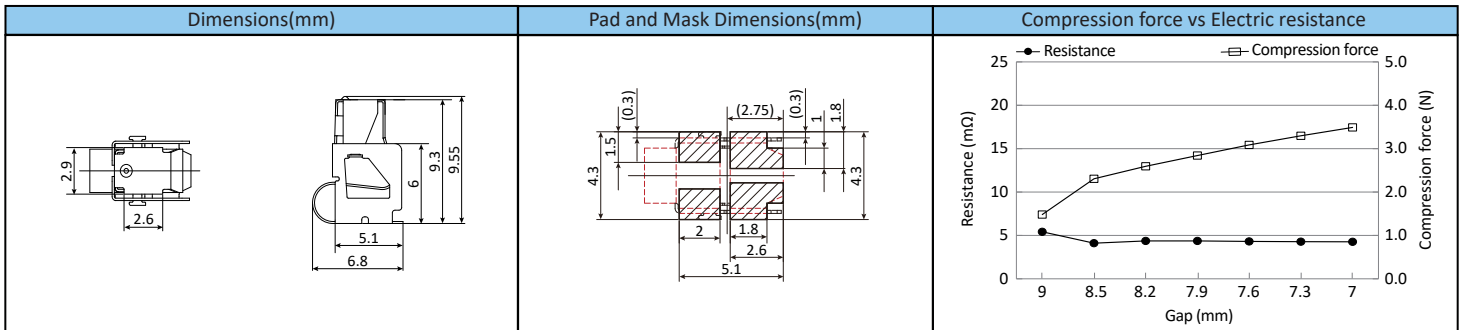

Compression Test

Deflection: H=7.0mm~7.6mm
 Compression count : 10 million times
 Compression speed: 100 times/sec
 Test method: Height measured and visual check after compressed to 7.0mm~7.6mm
 10 million deflections.

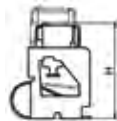

	Before	After
External status		
Height (mm)	9.619	9.601
Recovery rate (%)	—	99.8

Heat-shock Test

Temperature switch: -40°C/150°C (0.5 hour each)
 Number of cycle: 2000 cycles
 Metal plate: Aluminum (ADC 12)
 Test method: Sample is compressed by metal plate while heat is applied.
 DC resistance value is measured.

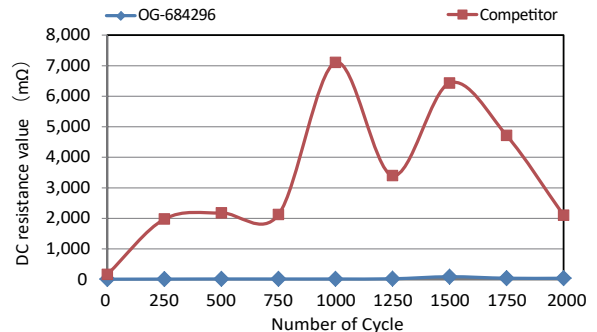

All statements, specifications, properties, technical information, and recommendations herein are based on tests; however, the accuracy and completeness are not guaranteed and are subject to change without notice due to product improvement and specification change. This statement is made in lieu of all warranties, expressed or implied, including the implied warranties of marketability, and fitness for purpose. KITAGAWA INDUSTRIES America, Inc. obligation under this warranty shall be limited to replacement of product that proves to be defective. Prior to use, the user shall determine the suitability of the product for its intended use, and the user assumes all risk and liability whatsoever in connection therewith. KITAGAWA INDUSTRIES America, Inc. shall have no liability for any injury, loss, or damage arising out of the use of or the inability to use the products. No statement or recommendation contained herein shall have any force or effect unless in an agreement signed by officers of seller and manufacturer.

KGS KITAGAWA INDUSTRIES America, Inc.
 2860 Zanker Road Suite 102, San Jose, CA 95134
 Tel: 1-855-EMC-PART (1-855-362-7278) Email: sales@kgs-ind.com

www.kgs-ind.com

Please request for detailed product specification data prior to purchase

Volume resistivity stated on our EMI absorber flyer is meant for noise control parameters, where the absorber is considered a conductor, but not for insulation performance. Care should be taken when using absorbers. KITAGAWA INDUSTRIES America, Inc. makes no guarantees as to electrical resistivity values and accepts no liability due to short circuits where EMI absorbers are used directly on a PC Board or areas near high voltage such as for power. The products are designed for EMI noise reduction for electronics. This is not recommended for applications involving human life or extremely high accuracy. Prior to using the products in production, please verify their performance or adhesive strength of PSA for long term use. Avoid applying any external stress such as bending or high amounts of tension. Note when the absorber products are cut, bent, or pulled, there may be a possibility of creating cracks. For storage, keep products in a cool, dry, well-ventilated area at room temperature and avoid high temperatures, humidity, and direct sunlight.

Please contact the sales department at KITAGAWA INDUSTRIES America, Inc. for the use of our products prior to selecting the parts for your application.

Onboard Contact_OG-684296_REV0_01242019

NEW!

On-Board Clip OGCP-502423



Automated mounting applicable fixture “On-Board Clip” for shielding can

- Clip structure enables easy removal of shielding can
- Multi-point GND is provided to shielding can and reinforced shielding performance
- Wide opening (A) provides easy insertion of a shielding can

Specifications

Applications	Ground clip for SMD
Material	Phosphor bronze for spring (t0.12mm)
Applicable Thickness (mm)	t0.28 ~ 0.56
Surface Treatment	Sn reflow plating
Operating Temperature (°C)	-40 ~ 125

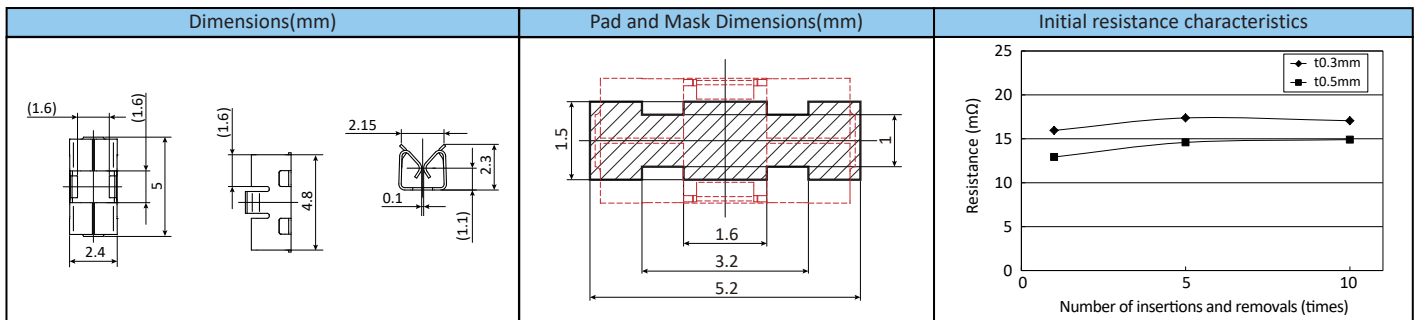
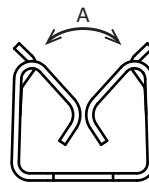

Application

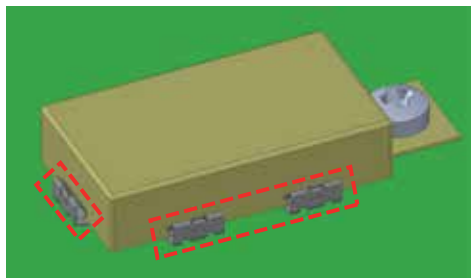

* Holding of a shielding can using only the clips is not guaranteed.

Shielding Properties

Before and after Heat Cycle Test

Test condition: -40°C (2h) ~ 125°C (2h) x 167 cycles

Test method: OGCP-502423 is installed at four locations surrounding the on-board antenna

Radiation noise that is emitted from inside of the shielding can is measured before and after the heat cycle test.

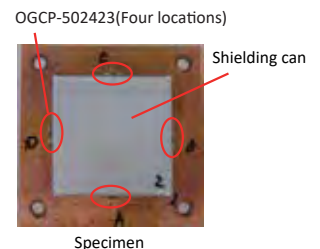
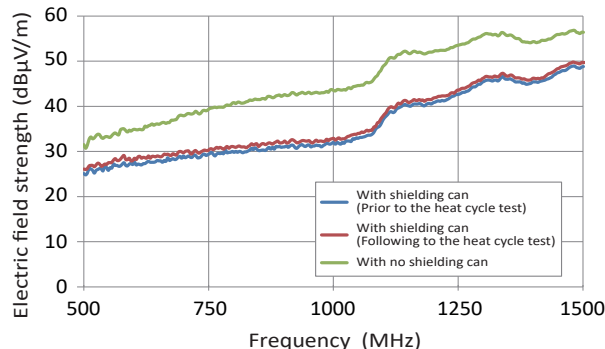

All statements, specifications, properties, technical information, and recommendations herein are based on tests; however, the accuracy and completeness are not guaranteed and are subject to change without notice due to product improvement and specification change. This statement is made in lieu of all warranties, expressed or implied, including the implied warranties of marketability, and fitness for purpose. KITAGAWA INDUSTRIES America, Inc. obligation under this warranty shall be limited to replacement of product that proves to be defective. Prior to use, the user shall determine the suitability of the product for its intended use, and the user assumes all risk and liability whatsoever in connection therewith. KITAGAWA INDUSTRIES America, Inc. shall have no liability for any injury, loss, or damage arising out of the use of or the inability to use the products. No statement or recommendation contained herein shall have any force or effect unless in an agreement signed by officers of seller and manufacturer.

KGS KITAGAWA INDUSTRIES America, Inc.
2860 Zanker Road Suite 102, San Jose, CA 95134
Tel: 1-855-EMC-PART (1-855-362-7278) Email: sales@kgs-ind.com

www.kgs-ind.com

Please request for detailed product specification data prior to purchase

Volume resistivity stated on our EMI absorber flyer is meant for noise control parameters, where the absorber is considered a conductor, but not for insulation performance. Care should be taken when using absorbers. KITAGAWA INDUSTRIES America, Inc. makes no guarantees as to electrical resistivity values and accepts no liability due to short circuits where EMI absorbers are used directly on a PC Board or areas near high voltage such as for power. The products are designed for EMI noise reduction for electronics. This is not recommended for applications involving human life or extremely high accuracy. Prior to using the products in production, please verify their performance or adhesive strength of PSA for long term use. Avoid applying any external stress such as bending or high amounts of tension. Note when the absorber products are cut, bent, or pulled, there may be a possibility of creating cracks. For storage, keep products in a cool, dry, well-ventilated area at room temperature and avoid high temperatures, humidity, and direct sunlight.

Please contact the sales department at KITAGAWA INDUSTRIES America, Inc. for the use of our products prior to selecting the parts for your application.

On-Board Clip_OGCP-502423_REV0_06182018

On-Board EMC Grounding Contacts



SMT contacts for PCB-level EMC grounding, shielding, and ESD solution

- Effective for emission and ESD immunity reduction
- All EMC mitigation can be done at the board-level
- Specially designed to prevent damage of springs
- Space-saving and robust design, easy to incorporate even where screws are included
- Tape-and-reel design allows for use with automated pick-and-place machine to increase efficiency and reduce manual labor

Application examples

Grounding between two PCBs

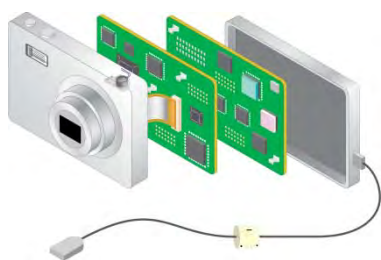

ESD solution at connector

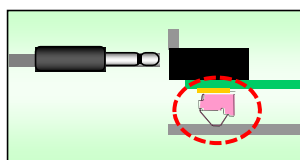

Grounding between PCB and enclosure



Test experiment – How to ground effectively

Test PC board condition

Radiated emissions test

- 1) PCB with no grounding
- 2) PCB + four points ground (at A, B, C, D)
- 3) PCB + eight points ground (at A, B, C, D, E, F, G, H)

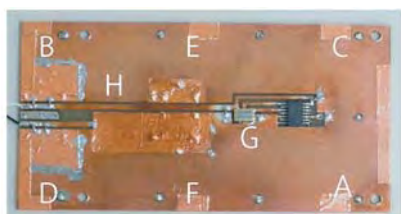

FG points point on PCB



Test result

Multiple grounding points noise suppression better even at higher frequencies.

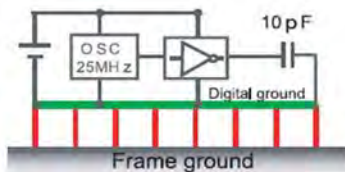

* Recommended EMC grounding pitch is 1/8 of the wavelength of the target (problem) frequency.

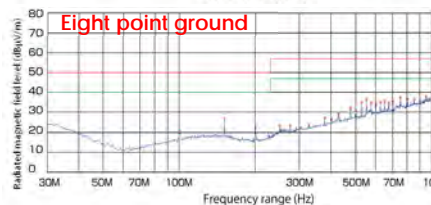
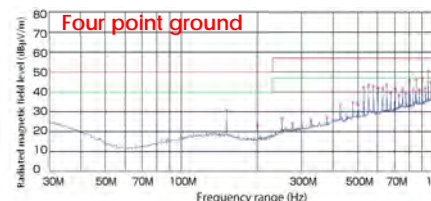
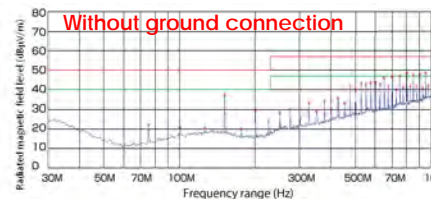

KITAGAWA INDUSTRIES America, Inc.
2325 Paragon Drive, Suite 10, San Jose, CA 95131
Tel: (408) 971-2055 Fax: (408) 971-6033
www.kgs-ind.com

All statements, technical information, and recommendations herein are based on tests and are believed to be reliable, but the accuracy and completeness are not guaranteed and are subject to change without notice due to product improvement and specification change. The following is made in lieu of all warranties, expressed or implied, including the implied warranties of marketability and fitness for purpose. Intermark USA's obligation under this warranty shall be limited to replacement of product that proves to be defective. Before using, user shall determine the suitability of the product for its intended use, and user assumes all risk and liability whatsoever in connection therewith. Intermark USA shall have no liability for any injury, loss or damage arising out of the use of or the inability to use the products. No statement or recommendation not contained herein shall have any force or effect agreement signed by officers of seller and manufacturer.

The specifications and properties regarding performance above are not guaranteed, and are subject to change without notice due to product improvement and specification change. While our absorbers are electrically non-conductive, usage directly on the PC Board near the power should be carefully checked. Intermark (USA) Inc. makes no guarantees as to electrical resistivity values and accepts no liability due to short circuits where EMI absorbers are used directly on a PC Board. The products are designed for EMI noise reduction for electronics. This is not recommended to use for applications involving human life or extremely high accuracy. Prior to your usage of the products in production, please verify their performance of EMI noise absorption or adhesive strength of PSA for long term use. Avoid applying any external stress such as bending or high amounts of tension. Note that when the absorber products are cut, bent or pulled, there might be some possibility of creating cracks. For storage of the products keep them in cool and dry rooms at ambient temperature avoiding high temperatures, humidity, and direct sunlight. Keep in a cool, dry, well ventilated place.

Standard On-Board Contacts – For parallel EMC grounding

NEW!!

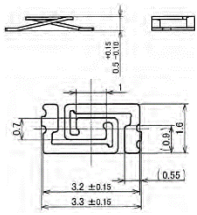

Part Number	OG-321605
Length	3.2 mm
Width	1.6 mm
Height	0.5 mm
Recommended Gap	0.35 mm or less
Base Material	Phosphor Bronze
Surface Treatment	Sn plating, Cu undercoat
Qty per Reel	4,000 pcs

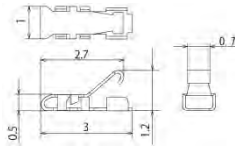

Part Number	OG-301012
Length	3.0 mm
Width	1.0 mm
Height	1.2 mm
Recommended Gap	0.6~1.1 mm
Base Material	Phosphor Bronze
Surface Treatment	Partial Au plating, Ni undercoat
Qty per Reel	8,000 pcs

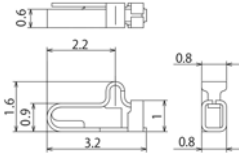

Part Number	OG-320816
Length	3.2 mm
Width	0.8 mm
Height	1.6 mm
Recommended Gap	1.1~1.4 mm
Base Material	Phosphor Bronze
Surface Treatment	Partial Au plating, Ni undercoat
Qty per Reel	8,000 pcs

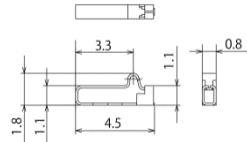

Part Number	OG-450818
Length	4.5 mm
Width	0.8 mm
Height	1.8 mm
Recommended Gap	1.2~1.6 mm
Base Material	Beryllium Copper
Surface Treatment	Partial Au plating, Ni undercoat
Qty per Reel	8,000 pcs

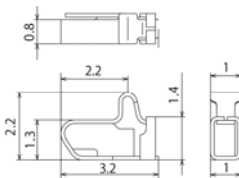

Part Number	OG-321022
Length	3.2 mm
Width	1.0 mm
Height	2.2 mm
Recommended Gap	1.5~2 mm
Base Material	Phosphor Bronze
Surface Treatment	Partial Au plating, Ni undercoat
Qty per Reel	7,000 pcs

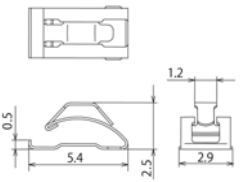

Part Number	OG-542925
Length	5.4 mm
Width	2.9 mm
Height	2.5 mm
Recommended Gap	1.5~2.3 mm
Base Material	Phosphor Bronze
Surface Treatment	Partial Au plating, Ni undercoat
Qty per Reel	5,000 pcs

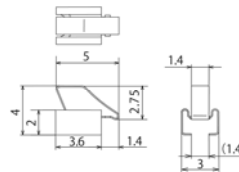

Part Number	OG-363040
Length	3.6 mm
Width	3.0 mm
Height	4.0 mm
Recommended Gap	2.2~3.4 mm
Base Material	Beryllium Copper
Surface Treatment	One side Sn plating, Ni undercoat
Qty per Reel	1,000 pcs

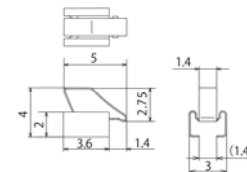

Part Number	OG-363040G
Length	3.6 mm
Width	3.0 mm
Height	4.0 mm
Recommended Gap	2.2~3.4 mm
Base Material	Beryllium Copper
Surface Treatment	Partial Au plating, Ni undercoat
Qty per Reel	1,000 pcs

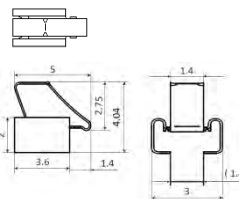

Part Number	OG-363040HD
Length	3.6 mm
Width	3.0 mm
Height	4.04 mm
Recommended Gap	2.2~3.4mm
Base Material	Beryllium Copper
Surface Treatment	One side Sn plating, Ni undercoat
Qty per Reel	2,400 pcs

NEW!!

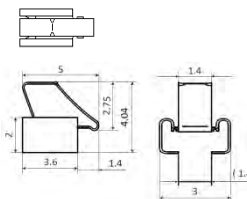

Part Number	OG-363040HDR
Length	3.6 mm
Width	3.0 mm
Height	4.04 mm
Recommended Gap	2.2~3.4mm
Base Material	Phosphor Bronze
Surface Treatment	Sn plating, Cu undercoat
Qty per Reel	2,400 pcs

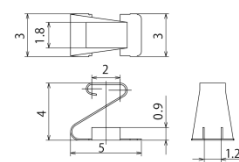

Part Number	OG-503040
Length	5.0 mm
Width	3.0 mm
Height	4.0 mm
Recommended Gap	2.2~3.6 mm
Base Material	Beryllium Copper
Surface Treatment	Sn plating, Ni undercoat
Qty per Reel	1,000 pcs

NEW!!

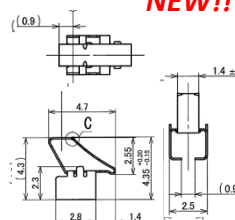

Part Number	OG-282543HDR
Length	2.8 mm
Width	2.5 mm
Height	4.35 mm
Recommended Gap	2.5~3.9 mm
Base Material	Phosphor Bronze
Surface Treatment	Sn plating, Cu undercoat
Qty per Reel	5,000 pcs

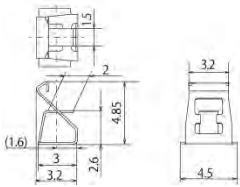

Part Number	OG-453048
Length	3.0 mm
Width	4.5 mm
Height	4.85 mm
Recommended Gap	2.7~4.4 mm
Base Material	Phosphor Bronze
Surface Treatment	Sn plating, Cu undercoat
Qty per Reel	2,000 pcs

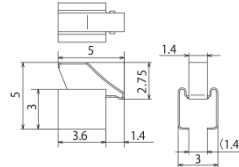

Part Number	OG-363050
Length	3.6 mm
Width	3.0 mm
Height	5.0 mm
Recommended Gap	3.2~4.4 mm
Base Material	Beryllium Copper
Surface Treatment	One side Sn plating, Ni undercoat
Qty per Reel	1,000 pcs

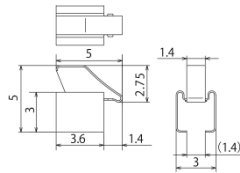

Part Number	OG-363050G
Length	3.6 mm
Width	3.0 mm
Height	5.0 mm
Recommended Gap	3.2~4.4 mm
Base Material	Beryllium Copper
Surface Treatment	Partial Au plating, Ni undercoat
Qty per Reel	1,000 pcs

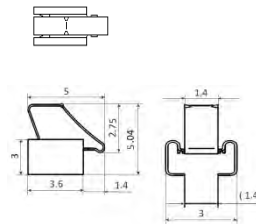

Part Number	OG-363050HD
Length	3.6 mm
Width	3.0 mm
Height	5.04 mm
Recommended Gap	3.2~4.4 mm
Base Material	Beryllium Copper
Surface Treatment	One side Sn plating, Ni undercoat
Qty per Reel	2,000 pcs

NEW!!

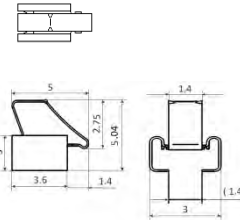

Part Number	OG-363050HDR
Length	3.6 mm
Width	3.0 mm
Height	5.04 mm
Recommended Gap	3.2~4.4 mm
Base Material	Phosphor Bronze
Surface Treatment	Sn plating, Cu undercoat
Qty per Reel	2,000 pcs

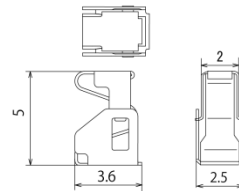

Part Number	OG-362550
Length	3.6 mm
Width	2.5 mm
Height	5.0 mm
Recommended Gap	3.6~4.5 mm
Base Material	Phosphor Bronze
Surface Treatment	Sn plating, Cu undercoat
Qty per Reel	2,000 pcs

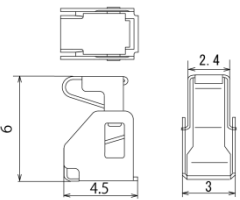

Part Number	OG-453060
Length	4.5 mm
Width	3.0 mm
Height	6.0 mm
Recommended Gap	4.2~5.5 mm
Base Material	Phosphor Bronze
Surface Treatment	Sn plating, Cu undercoat
Qty per Reel	1,500 pcs

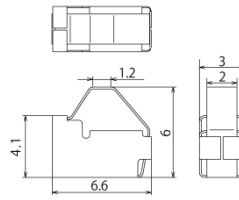

Part Number	OG-603060
Length	6.6 mm
Width	3.0 mm
Height	6.0 mm
Recommended Gap	4.2~5.5 mm
Base Material	Phosphor Bronze
Surface Treatment	Sn plating
Qty per Reel	850 pcs

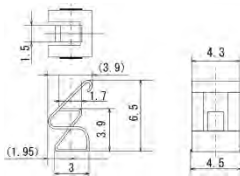

Part Number	OG-453065
Length	3.0 mm
Width	4.5 mm
Height	6.5 mm
Recommended Gap	4.2~6.0 mm
Base Material	Phosphor Bronze
Surface Treatment	Sn plating, Cu undercoat
Qty per Reel	1,500 pcs

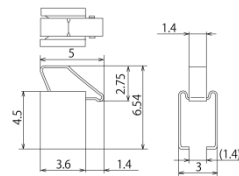

Part Number	OG-363065HD
Length	3.6 mm
Width	3.0 mm
Height	6.54 mm
Recommended Gap	4.7~5.9 mm
Base Material	Beryllium copper
Surface Treatment	One side Sn plating, Ni undercoat
Qty per Reel	1,000 pcs

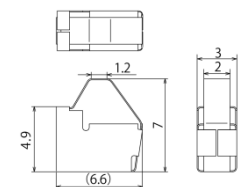

Part Number	OG-603070
Length	6.6 mm
Width	3.0 mm
Height	7.0 mm
Recommended Gap	5~6.5 mm
Base Material	Phosphor Bronze
Surface Treatment	Sn plating
Qty per Reel	750 pcs

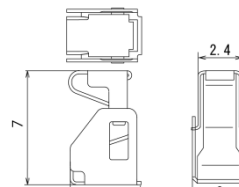

Part Number	OG-453070
Length	4.5 mm
Width	3.0 mm
Height	7.0 mm
Recommended Gap	5.3~6.5 mm
Base Material	Phosphor Bronze
Surface Treatment	Sn plating, Cu undercoat
Qty per Reel	1,500 pcs

Automotive-Grade – on-board grounding contact and shield-can clip

- Designed and tested to withstand conditions common in the auto industry

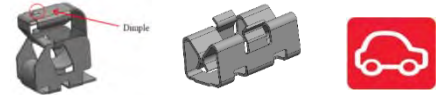

NEW!!

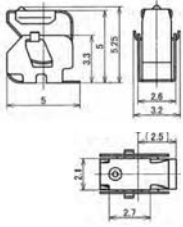

Part Number	OG-503253-A
Length	5.0 mm
Width	3.2 mm
Height*	5.25 mm
Recommended Gap	3.5~4.5 mm
Base Material	Beryllium Copper
Surface Treatment	Sn plating, Cu undercoat
Qty per Reel	2,000 pcs
Operating Temperature	-40~150°C

* Dimple included on the top surface of OG-503253-A to maintain metal-to-metal connection during vibration.

NEW!!

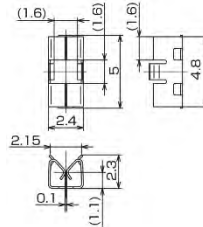

Part Number	OGCP-502423
Length	5.0 mm
Width	2.4 mm
Height	2.3 mm
Base Material	Phosphor Bronze
Recommended Shield-Can Thickness	0.28~0.56 mm
Surface Treatment	Sn plating
Qty per Reel	6,000 pcs
Operating Temperature	-40~125°C

Shielding-can clips: OGCP series

- Allows for easy installation and removal of shield-cans for quick inspections and re-work
- Maintains the same shielding effectiveness as complete perimeter soldering

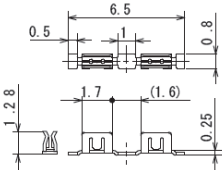

Part Number	OGCP-650813R
Length	6.5 mm
Width	0.8 mm
Height	1.28 mm
Base Material	Phosphor Bronze
Recommended Shield-Can Thickness	0.15~0.2 mm
Surface Treatment	Cu undercoat, Sn plating
Qty per Reel	8,000 pcs

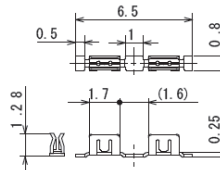

Part Number	OGCP-650813G
Length	6.5 mm
Width	0.8 mm
Height	1.28 mm
Base Material	Titanium Copper
Recommended Shield-Can Thickness	0.15±0.03 mm
Surface Treatment	Ni undercoat, one side Au plating
Qty per Reel	8,000 pcs

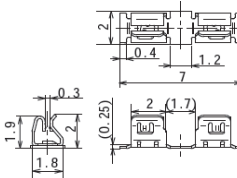

Part Number	OGCP-702020
Length	7.0 mm
Width	2.0 mm
Height	2.0 mm
Base Material	Phosphor Bronze
Recommended Shield-Can Thickness	0.3±0.02 mm
Surface Treatment	Cu undercoat, Sn plating
Qty per Reel	9,000 pcs

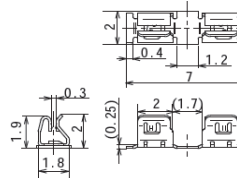

Part Number	OGCP-702020G
Length	7.0 mm
Width	2.0 mm
Height	2.0 mm
Base Material	Phosphor Bronze
Recommended Shield-Can Thickness	0.3±0.02 mm
Surface Treatment	Ni undercoat, Au plating
Qty per Reel	9,000 pcs

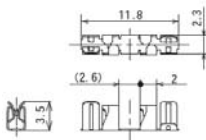

Part Number	OGCP-1182435
Length	11.8 mm
Width	2.4 mm
Height	3.5 mm
Base Material	Phosphor Bronze
Recommended Shield-Can Thickness	0.3±0.02 mm
Surface Treatment	Cu undercoat, Sn plating
Qty per Reel	3,000 pcs

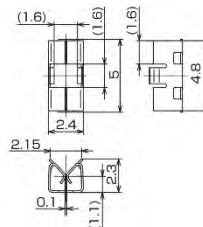

Part Number	OGCP-502423 *
Length	5.0 mm
Width	2.4 mm
Height	2.3 mm
Base Material	Phosphor Bronze
Recommended Shield-Can Thickness	0.28~0.56 mm
Surface Treatment	Sn plating
Qty per Reel	6,000 pcs

* Automotive Grade

How to Use OGCP Clips with Shield-Cans



Shield-can clips reflow soldered onto PCB

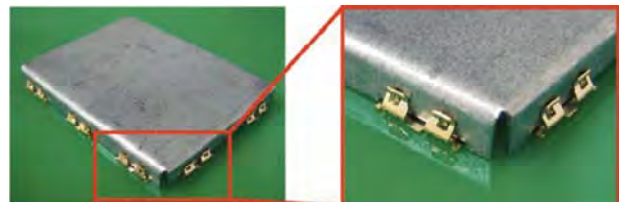

Install shield-cans with a machine or jig to avoid inserting the can on an angle.

Board-level wire management clamps: OGC Series

- Designed to manage thin cables on the PC board
- For EMC grounding, a metal ferrule can be used in conjunction with the OGC clamp
- Available in side or top insertion

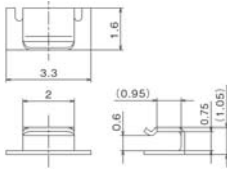
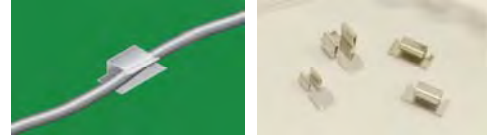

Part Number	OGC-331610
Length	3.3 mm
Width	1.6 mm
Height	1.0 mm
Recommended Wire Diameter	Ø 0.8 mm
Base Material	Phosphor Bronze
Surface Treatment	Sn plating
Qty per Reel	3,000 pcs

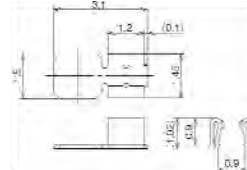

Part Number	OGC-311510U
Length	3.1 mm
Width	1.5 mm
Height	1.0 mm
Recommended Wire Diameter	Ø 0.8 mm
Base Material	Phosphor Bronze
Surface Treatment	Sn plating
Qty per Reel	3,000 pcs

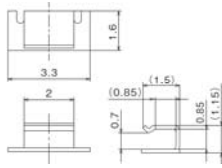

Part Number	OGC-331612
Length	3.3 mm
Width	1.6 mm
Height	1.2 mm
Recommended Wire Diameter	Ø 0.86 mm
Base Material	Phosphor Bronze
Surface Treatment	Sn plating
Qty per Reel	2,500 pcs

NEW!!

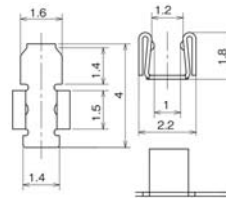

Part Number	OGC-224018U
Length	2.2 mm
Width	4.0 mm
Height	1.8 mm
Recommended Wire Diameter	Ø 1.3~1.4 mm
Base Material	Phosphor Bronze
Surface Treatment	Sn plating, Cu undercoat
Qty per Reel	7000 pcs

Side contacts for perpendicular grounding: OGSC Series

- Ideal for applications where EMC grounding between two parallel boards or chassis is not possible but a perpendicular ground is possible
- Unique design allows for lateral sliding without damaging contacts

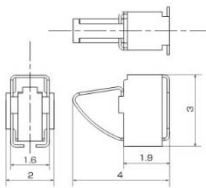

Part Number	OGSC-402030
Length (with spring)	4.0 mm (total)
Width	2.0 mm
Height	3.0 mm
Recommended Side Gap	0.4~1.6 mm
Base Material	Phosphor Bronze
Surface Treatment	Sn plating, Cu undercoat
Qty per Reel	5,000 pcs

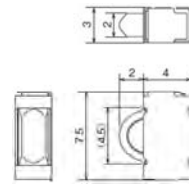

Part Number	OGSC-756030
Length	7.5 mm
Width (with spring)	6 mm (total)
Height	3.0 mm
Recommended Side Gap	Up to 2 mm
Base Material	Phosphor Bronze
Surface Treatment	Sn plating
Qty per Reel	2,000 pcs

Coil spring on-board contact: OGSR Series

- Vibration-resistant contact maintains good grounding even after repeated compressions.



OGSR-506080	
	Restoration Rate
Av.(%)	98.7
Max.(%)	99.89
Min.(%)	97.13
Sample.(pcs)	10

Restoration after 100,000 compressions

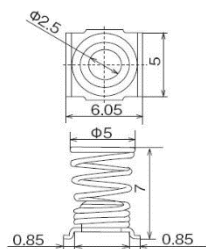
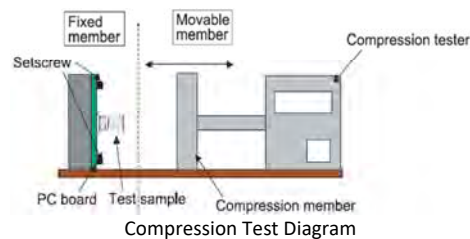

Part Number	OGSR-506070
Recommended Gap	4.7~6.5 mm
Base Material	(a): Piano wire, (b): Brass
Surface Treatment	(a): Partial Au plating, Cu and Ni undercoat (b): Partial Sn plating, Ni undercoat
Qty per Reel	1,000 pcs

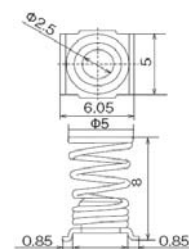

Part Number	OGSR-506080
Recommended Gap	5.0~7.5 mm
Base Material	(a): Piano wire, (b): Brass
Surface Treatment	(a): Partial Au plating, Cu and Ni undercoat (b): Partial Sn plating, Ni undercoat
Qty per Reel	900 pcs

On-board plates for reliable grounding contact: OGP Series

- Eliminates problems with bad contact due to soldering flux
- Ensures reliable, stable electrical contact for EMC grounding

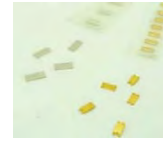

	Part Number	OGP-3216
	Base Material	Brass
	Thickness	0.1 mm
	Surface Treatment	Ni undercoat, Au plating
	Qty per Reel	5,000 pcs

	Part Number	OGP-4520
	Base Material	Brass
	Thickness	0.15 mm
	Surface Treatment	Cu undercoat, Sn plating
	Qty per Reel	3,000 pcs

Recommended Uses of OGP Plates

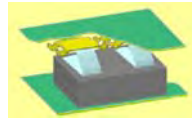

On-board contact reinforcement

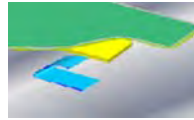

Frame-ground reinforcement



Substitute for washer and lug terminal

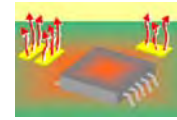

PCB cooling

Lug terminals to ensure grounding at screws: OG-R Series

- For reliable and stable electrical grounding when applied at screw holes
- Helps to prevent EMC grounding reduction from loosened screws

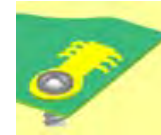

	Part Number	OG-RM26
	Base Material	Brass
	Material Thickness	0.4 mm
	Surface Treatment	Ni undercoat, Sn plating
	Applicable Screw Hole	M3
	Qty per Reel	8,000 pcs

	Part Number	OG-R26 SN
	Base Material	Tough Pitch Copper
	Material Thickness	0.1 mm
	Surface Treatment	Cu undercoat, Sn plating
	Applicable Screw Hole	M3
	Qty per Reel	2,000 pcs

	Part Number	OG-RM30F
	Base Material	Tough Pitch Copper
	Material Thickness	0.3 mm
	Surface Treatment	Ni undercoat, Sn plating
	Applicable Screw Hole	M4
	Qty per Reel	3,000 pcs

	Part Number	OG-R30 SN
	Base Material	Tough Pitch Copper
	Material Thickness	0.1 mm
	Surface Treatment	Cu undercoat, Sn plating
	Applicable Screw Hole	M4
	Qty per Reel	2,000 pcs

	Part Number	OG-RM30HF
	Base Material	Tough Pitch Copper
	Material Thickness	0.3 mm
	Surface Treatment	Ni undercoat, Sn plating
	Applicable Screw Hole	M4
	Qty per Reel	3,000 pcs

High-point contact for large gap spaces: HPC Series

- Tall profile fits gap spaces from 10~20mm
- Spring design maintains electrical contact after compression
- Use a M3 screw to secure in place
- Tape-mount option available

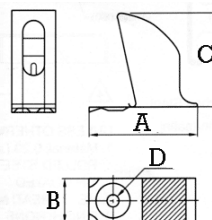

Part Number	HPC-10-20 (HPC-10-20T*)
A (Length)	25.0 mm
B (Width)	10.0 mm
C (Height)	22.5 mm
D (Screw Hole)	M3
Base Material	Stainless Steel
Recommended Gap	10~20 mm
Qty per Box	100 pcs

* HPC-10-20T is the tape-mount version.

EMC Grounding Components



Prior to using KGS part, please read our "Product Important Notice" at <http://kgs-ind.com/products/product-important-notice/>

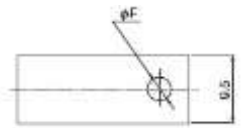
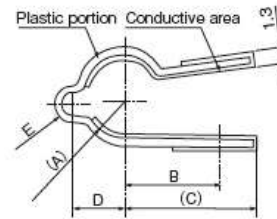

FGC for M3 and M4 Screw Size (units in mm)

Part Number	FGC-3 FGC-3 M4	FGC-5 FGC-5 M4	FGC-8 FGC-8 M4
A	R1.8	R3.0	R4.8
B	9.5	10.7	12.5
(C)	13.5	14.7	16.6
D	3.0m	4.3	6.5m
E	R1.5	R2.0	R.2.3
F	M3 diameter: 3.2 M4 diameter: 4.2		
Applicable cable diameter	2.7~3.5	5.0~5.5	8.2~9.0
Plastic material	Nylon 66 (light gray/UL 94V-0)		
Metal material and thickness	Copper 0.03mm		
Operating temperature	-10~65°C		

Frame Grounding Cable Clamps (FGC Series)

- Provides simultaneous fastening and grounding for coaxial and braid-shielded cables.
- Resin base plated with copper foil.
- High quality materials prevent the clamp from damaging the cable shielding or the insulation sleeve.
- Excellent flexibility insures constant contact pressure and stable contact resistance under heat variation and heavy vibration conditions.
- The contact resistance of the highly conductive copper layer is lower than the nickel or chromium plating on the standard metallic clamps.
- Low weight and space saving solution for dedicated cable grounding.
- Fastening and grounding on power and signal round cables in various applications where electrical connection between the cable and the grounding circuit is required for EMI shielding or ESD suppression.

New!



Frame Grounding Wire Clamps (FGCS)

- Combination of grounding and clamping with the FG series reduces the overall number of components in an application.
- Plastic and metal portions can be separated for disposal.
- Cables easily detach for improved ease of maintenance.

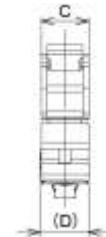
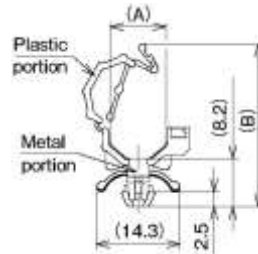

(units in mm)

Part Number	FGCS-5	FGCS-8
(A)	7.0	9.5
(B)	23.3	27.5
C	5.5	8.5
(D)	5.7	8.7
Recommended board thickness	0.8~1.6	
Applicable cable diameter	5.0~5.5	7.0~8.5
Mounting hole dimensions	4.8 ±0.2	
Plastic material	Nylon 66 (Natural/ UL94V-0)	
Metal material	Tin plated phosphor bronze	
Flame resistance	UL94V-0	

Please request for a specification sheet for detailed product data prior to purchase.



KITAGAWA INDUSTRIES America, Inc.
 2325 Paragon Drive, Suite 10, San Jose, CA 95131
 Tel: (408) 971-2055 Fax: (408) 971-6033
 www.kgs-ind.com sales@kgs-ind.com

All statements, specifications, properties, technical information, and recommendations herein are based on tests; however, the accuracy and completeness are not guaranteed and are subject to change without notice due to product improvement and specification change. This statement is made in lieu of all warranties, expressed or implied, including the implied warranties of marketability, and fitness for purpose. KITAGAWA INDUSTRIES America, Inc. obligation under this warranty shall be limited to replacement of product that proves to be defective. Prior to use, the user shall determine the suitability of the product for its intended use, and the user assumes all risk and liability whatsoever in connection therewith. KITAGAWA INDUSTRIES America, Inc. shall have no liability for any injury, loss, or damage arising out of the use of or the inability to use the products. No statement or recommendation contained herein shall have any force or effect unless in an agreement signed by officers of seller and manufacturer.

Volume resistivity stated on our EMI absorber flyer is meant for noise control parameters, where the absorber is considered a conductor, but not for insulation performance. Care should be taken when using absorbers. KITAGAWA INDUSTRIES America, Inc. makes no guarantees as to electrical resistivity values and accepts no liability due to short circuits where EMI absorbers are used directly on a PC Board or areas near high voltage such as for power. The products are designed for EMI noise reduction for electronics. This is not recommended for applications involving human life or extremely high accuracy. Prior to using the products in production, please verify their performance or adhesive strength of PSA for long term use. Avoid applying any external stress such as bending or high amounts of tension. Note when the absorber products are cut, bent, or pulled, there may be a possibility of creating cracks. For storage, keep products in a cool, dry, well-ventilated area at room temperature and avoid high temperatures, humidity, and direct sunlight.

Please contact the sales department at KITAGAWA INDUSTRIES America, Inc. for the use of our products prior to selecting the parts for your application.

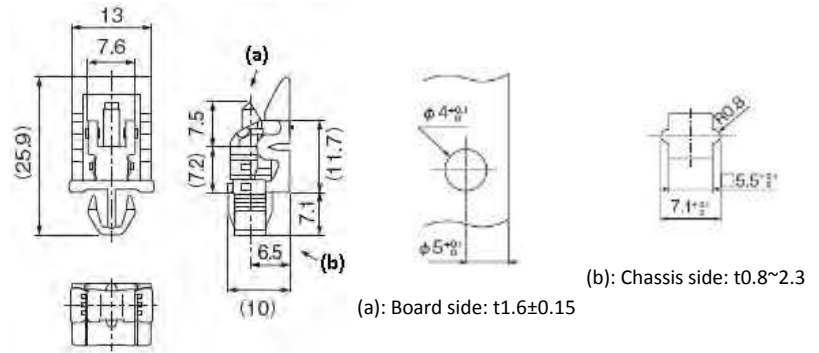

Frame Grounding Edge Spacer (FGES Series)

- Provides simultaneous support and grounding with quick release capability for PC board assemblies where frequent inspection or removal is expected.
- Light-weight PPE resin base provided with a tinned phosphor bronze conductive strip.
- High quality materials with excellent flexibility provide constant contact pressure and stable contact resistance under heat variation and heavy vibration conditions.
- Single piece with snap-on mounting capability - materials and labor saving solution to replace the classical screw assembled metal spacers.
- Snap-on card edge spacers provide support for printed circuit boards with quick release capability in applications where electrical connection between elements is required for EMI shielding or ESD suppression.
- Ideal labor saving solution for high volume electronic packaging applications.
- Compatible for using in combination with various types of hinged card spacers and corner posts (PHD-10 and KGCP-10).

(units in mm)

Part Number	FGES-10
Recommended board thickness	(a): 1.6 ± 0.15 (b): $0.8 \sim 2.3$
Mounting hole diameter	(a): 4.0 (b): 4.8
Plastic material	PPHOX (Black/ UL94V-0)
Metal material and thickness	Tin plated phosphor bronze 0.2
Flame resistance	UL94V-0

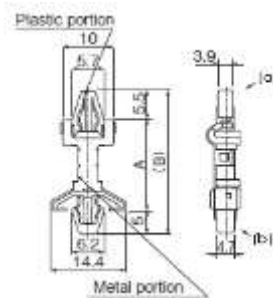

(units in mm)

Frame Grounding Spacers (FGS Series)

- Light-weight PPE resin base provided with a tinned phosphor bronze conductive strip.
- High quality materials with excellent flexibility insure constant contact pressure and stable contact resistance under heat variation and heave vibration conditions.
- Single piece with snap-on mounting capability - materials and labor saving solution to replace the classical screw assembled metal spacers.
- Convenient fitting on various inter-board spacing sizes.
- Snap-on card spacers provide support for printed circuit boards fastening to the chassis or base plates in applications where electrical connection between elements is required for EMI shielding or ESD suppression.
- Ideal labor saving solution for high volume electronic packaging applications.

Part Number	FGS-3S	FGS-4S	FGS-6S	FGS-8S	FGS-9S
A	9.8	11.4	14.4	17.7	20.0
B	20.3	21.9	24.9	28.2	30.5
Recommended board thickness	(a): $1.6 \sim 2.0$ (b): $1.0 \sim 2.0$				
Mounting hole diameter	(a): 4.0 (b): 4.8				
Plastic material	PPHOX (Black/ UL94V-0)				
Metal material	Tin plated phosphor bronze				
Flame resistance	UL94V-0				



Frame Grounding Wire Mesh Straps (FGM Series)

- Excellent impedance characteristics at high frequency range.
- Extra-thin flexible wire mesh with tin plated connection terminals
- Custom sized mesh straps available upon request.
- Various applications where electrical connection between fixed/mobile or removable elements of the assembly is required for EMI shielding or ESD suppression.

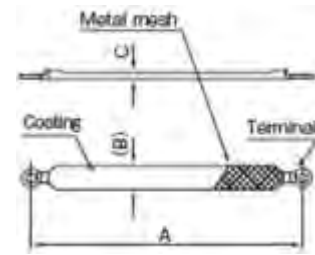

FGM for M3 and M4 Screw Size (units in mm)

Part Number	FGM-50	FGM-100	FGM-150	FGM-200
A	50.0	100.0	150.0	200.0
B	8.5			
C	2.5			
Material	Tin plated copper wire mesh			
Mounting options	Available in M3 or M4 size screw hole			
Insulation	Polyolefin shrink tubing (Terminals: R2-3 ring, standard for M3 size screw; M4-5 available on request)			



Frame Grounding Guide Rails (FGR Series)

- Molded black polycarbonate rail with spherical metal fingers provides simultaneous rigid guiding support and continuity of the ground draining circuit for the P.C. boards.
- Holds cards firmly on designated positions in the package while the pressure developed by the metal fingers insures constant contact between chassis and the printed circuit for excellent current package.
- Special spherical profile of the contact fingers prevents any scratching effect on the contact surface of the printed circuit (wiping action).
- Contact resistance does not vary in the heat cycle test and remains stable under heavy vibration conditions.
- Easy to assemble and fasten by snap-on rivet or screw mounting and very convenient for fast packaging and servicing operations.
- Guiding, fastening and grounding of P.C. boards in various single-card or rack-package applications where electrical connection between the circuit on board and the frame (chassis) is required for EMI shielding or ESD suppression.

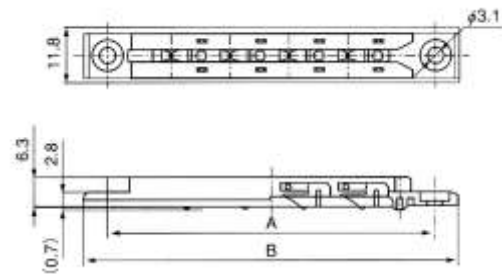

FGR for M3 Screw Size (units in mm)

Part Number	FGR-80WSP
A	70.0
B	80.0
Plastic material	Polycarbonate (Black/ UL94V-2)
Metal material and thickness	Tin plated phosphor bronze 0.2
Applicable board thickness	1.6 ±0.1
Flame resistance	UL94-V2 (UL94-V0 on request)

KITAGAWA INDUSTRIES GROUP

KITAGAWA INDUSTRIES GROUP is committed to supporting customers, and supply the most effective solutions for increased levels of EMC compliance required today by new international EMC regulations for computers, office equipment, telecommunication systems, local area networking, medical devices, digital imaging systems, automotive and aircraft equipment, as well as other unique applications.



KGS